

## W7100A-E Discharge Air Controller

The microprocessor based W7100 Discharge Air Controller maintains an average discharge air (DA) temperature in variable air volume (VAV) cooling systems by modulating an economizer and sequencing stages of mechanical cooling. The W7100 is also applicable to electrical makeup air and other systems requiring discharge air control of multistage heating or cooling.



- Available in cool only, heat only, heat/cool stage sequencing and modulating heat/cool.
- Staging capacity of the W7100A-C,E may be extended using a W7101A Satellite Sequencer.
- Advanced microprocessor control algorithms minimize droop.
- Adjustable control band from 2° F to 16° F [-17° C to -9° C].
- M8415 Damper Actuator provides two-position control: open and closed.
- Provision for systems without an economizer.
- Adjustable reset of DA setpoint within range of 5° F to 20° F [3° C to 11° C] upward on cooling, 20° F to 80° F [11° C to 44° C] upward on heating. Reset signal can be from space sensor or outdoor air sensor.
- Adjustable DA setpoint from 40° F to 90° F [4° C to 32° C] on cool only and heat/cool models; 40° F to 140° F [4° C to 60° C] on heat only and modulating heat/cool models.
- C7100 platinum resistance element provides highly accurate and stable DA temperature sensing.
- LEDs on W7100 A,B,C, and E panels show which stages of heating or cooling are on.
- W7100D has single selectable modulating output, either heat or cool.

### CONTENTS

Specifications .....	2
Ordering Information .....	2
Installation .....	5
Operation .....	17
Settings and Adjustments .....	23
System Checkout .....	23

# Specifications

MODELS: W7100 Discharge Air Controller—see Table 1.

TABLE 1—W7100 DISCHARGE AIR CONTROLLER MODELS.

Model	Economizer	Modulating Heat Output	Modulating Cooling Output	Heating Stages <sup>a</sup>	Cooling Stages <sup>a</sup>	Temperature Range	
						°F	°C
W7100A	Yes	No	No	None	6	40° to 90°	4° to 32°
W7100B	Yes	No	No	6	None	40° to 140°	4° to 60°
W7100C	Yes	No	No	2	4	40° to 90°	4° to 32°
W7100D	Yes	Yes <sup>b</sup>	Yes <sup>b</sup>	None <sup>c</sup>	None <sup>c</sup>	40° to 140°	4° to 60°
W7100E	Yes	Yes	No	1	4	40° to 90°	4° to 32°

<sup>a</sup>Number of W7100 stages can be increased by six stages—four cool and two heat, or two cool and four heat, using W7101 Satellite Sequencer (except W7100E).

<sup>b</sup>W7100D has single selectable modulating output—either heat or cool.

<sup>c</sup>W7100D heating and cooling stages are not designed for use with the W7101 Satellite Sequencer.

## ELECTRICAL RATINGS:

Input Voltage and Frequency (terminals TR-TR): 20 to 30 Vac at 60 Hz; 20 to 26.4 Vac at 50 Hz.

Power Consumption: 12 VA at 24 Vac, 50 to 60 Hz.

Contacts	Voltage (V)	Inrush (VA)	Running (VA)
N.O.	24	240	60
N.C.	24	75	30
N.O.	120/240	750	75
N.C.	120/240	240	40

SWITCHING (on/off stages): Spdt relays.

WIRING TERMINALS: 1/4 in. [6 mm] quick-connect type.

INPUT SIGNAL (DA sensor): Positive temperature coefficient of 4.8 ohms/degree F [8.6 ohms/degree C], resistance of 3484 ohms at 77° F [25° C].

CONTROLLED STAGES: Resistor value (across terminals 7 and 8) to determine number of on-off stages

controlled by W7100. Varies from 100 ohms for one stage to 1000 ohms for 10 stages with W7101 (see Table 2).

AMBIENT TEMPERATURE RANGE: -40° F to +150° F [-40°C to +60° C].

MOUNTING: Four mounting holes in base accept No. 8 screws (screws not provided).

DIMENSIONS: See Fig. 1.

## APPROVALS:

Underwriters Laboratories Inc. Component Recognized: Guide no. SDFY2, file no. SA481.

Canadian Standards Association Certified: Guide no. 400-E-0, file no. 46034.

## ADDITIONAL SYSTEM COMPONENTS:

C7100A1015 Discharge Air Averaging Sensor (required): Senses average DA temperature; provides input to W7100 sensor terminals T and T1.

Transformer (required): Provides 24 Vac power for all components of the W7100 Control System (size transformer to match system load).

# Ordering Information

When purchasing replacement and modernization products from your Honeywell distributor, refer to the TRADELINE® Catalog for complete ordering number.

If you have additional questions, need further information, or would like to comment on our products or services, please write or phone:

1. Your local Honeywell Home and Building Control Sales Office (check white pages of your phone directory).
2. Home and Building Control Customer Satisfaction  
 Honeywell Inc., 1885 Douglas Drive North  
 Minneapolis, Minnesota 55422-4386 (612) 951-1000

In Canada—Honeywell Limited/Honeywell Limitée, 740 Ellesmere Road, Scarborough, Ontario M1P 2V9 International Sales and Service Offices in all principal cities of the world. Manufacturing in Australia, Canada, Finland, France, Germany, Japan, Mexico, Netherlands, Spain, Taiwan, United Kingdom, U.S.A.

ACCESSORIES:

Model	Quantity	Description	Application
T7047C1025	As needed	Remote Set Point Temperature Sensor (15 ohms per degree F, 1495 ohms at 70° F.)	Discharge air temperature reset from controlled space. Use one or more T7047C1025 with each S963B1037.
S963B1037	As needed	Remote Setpoint Potentiometer	
C7031G1016	One	Outdoor Air Sensor (2.25 ohms per degree F, 1760 ohms at 70° F.)	Reset of discharge air from outdoor air temperature.
S963B1078	One	Remote Setpoint Potentiometer	Permits remote setpoint adjustment for W7100; 500 ohm, 40° F to 90° F [5° C to 32° C] temperature range.
S963B1086	One	Remote Setpoint Potentiometer	Permits remote setpoint adjustment for W7100; 1000 ohm, 40° F to 140° F [5° C to 60° C] temperature range.
M734 M954 M955	One	Economizer Motor-Valve Actuator. NOTE: 4074EAC Resistor Kit is necessary to convert M734D,G motor from 0 to 10 mA to 0 to 7 mA.	Opens OA damper when enthalpy of OA is below setpoint of enthalpy changeover controller for economizer control. Used as actuator for motorized valve in hot or chilled water applications.
H705	One	Solid State Enthalpy Changeover Controller	Permits adjustment of enthalpy changeover setpoint (outdoor air temperature and humidity) for economizer.
T675A	One	Dry Bulb Changeover	Permits adjustment of heat/cool changeover and morning warmup setpoints; T675A also used for reset lockout.
D640	Size as needed	Outdoor Air Damper	Controls outdoor airflow in economizer system. Requires economizer motor and Q605 Damper Linkage.
Q209A1030	One	Minimum Position Potentiometer	Permits adjustment of minimum damper position. Mounts on damper motor.
S963B1128	If desired	Remote Minimum Position Potentiometer	Permits remote setting of minimum damper position at location away from damper motor.
P246A1009	As needed	Static Pressure Regulator	Regulates static pressure in fan control systems.
V5011, V5013	As needed	Modulating Water Valve	Regulates flow of chilled or hot water to heat exchanger controlled by W7100D modulating output.
Q618	As needed	Linkage	Mechanical linkage between valve and actuator.
T6051	One	Night Setback Thermostat	Set to maintain minimum night space temperature.
C7100A1015	One	Averaging Discharge Air Temperature Sensor	Senses duct discharge air temperature for input to W7100.
W7101A1003	As needed	Satellite Sequencer	Adds up to six on/off stages of control (4 heat/2 cool, or 2 heat/4 cool) to W7100 system capability.
RP7517B1016	As needed	Electric/Pneumatic Transducer	Converts 2 to 10 Vdc signal of Q642A1008 Amplifier Output Module to 3 to 14 psi pressure signal for use in pneumatic actuated systems.

*(continued)*

ACCESSORIES (Continued):

Model	Quantity	Description	Application
Q642A1008	As needed	Amplifier Output Module	Converts modulating output signal of W7100 economizer or other modulating output to 2 to 10 Vdc voltage ramp.
AT72D1683 AT87A1106 AT88A1005 AT88A1021	As needed	System Transformer 40 VA, 120 Vac 50 VA, 120/208/240 Vac 75 VA, 120 Vac 75 VA, 208/240 Vac	Size VA to system load.
4074EAU	One, if desired	Resistor Kit	Unison drive of up to five Series 90 motors.
4074EDJ	If desired	Resistor Kit and Test Plug	Used in controller checkout.
4074EFV	One	Resistor Kit for W7101 Configuration	Used to select number of stages controlled.
L91B1035	One, if desired	Pressure Transducer	Converts RP913 signal for space reset in pneumatic systems. Used with W7100.
RP913	One, if desired	High/Low Pressure Signal Discriminator	Senses zone of highest demand for reset signal input to W7100.
Q605	As needed	Damper Linkage	Connects economizer actuator to damper.

Fig. 1—W7100 Discharge Air Controller mounting dimensions in in. [mm].

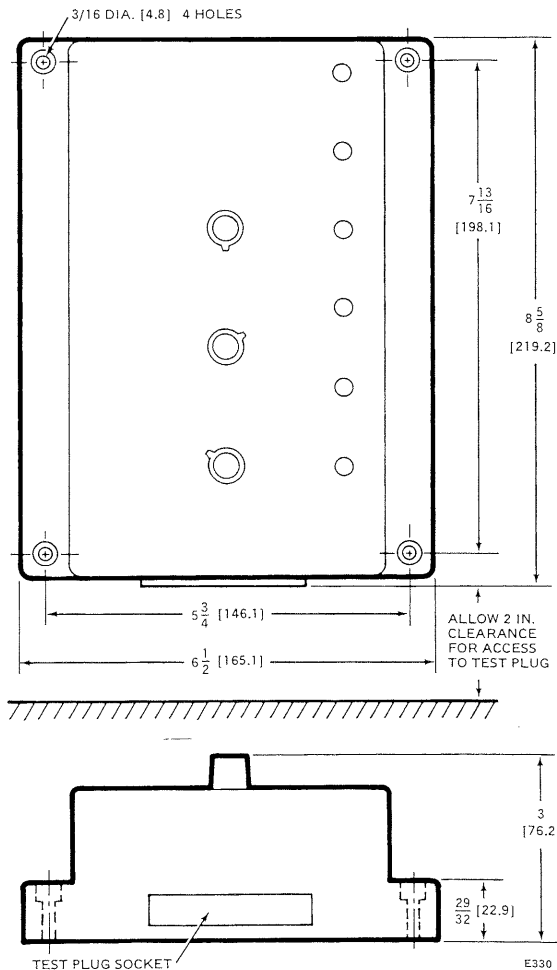
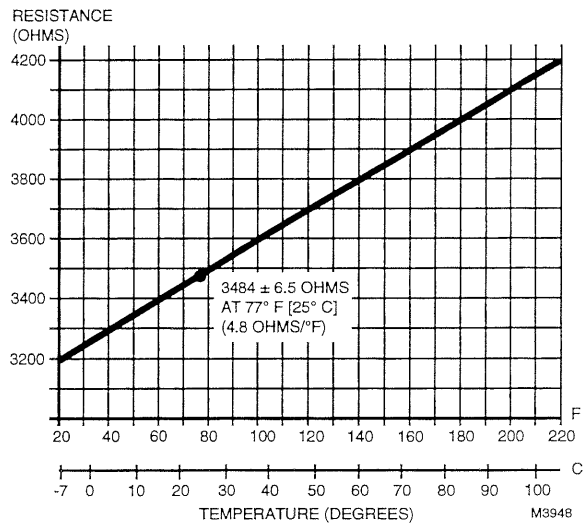

Fig. 2—Variation of C7100A Sensor resistance with temperature.



# Installation

## WHEN INSTALLING THIS PRODUCT...

1. Read these instructions carefully. Failure to follow them could damage the product or cause a hazardous condition.
2. Check the ratings and description given in this specification to make sure the product is suitable for your application.
3. Installer must be a trained, experienced service technician.
4. After installation is complete, check out product operation as provided in these instructions.



## CAUTION

1. Disconnect power supply before connecting wiring to prevent electrical shock or equipment damage.
2. To load any compressor, each compressor is running before cylinder unloaders are activated, when the W7100 is used in a system with multiple compressors. Apply hot gas by-pass controls to each compressor. To prevent compressor slugging and maintain the seasonal operating efficiency at the highest energy efficiency rating (EER), follow these recommendations.



## WARNING

This equipment generates, uses and can radiate radio frequency energy. If this equipment is not installed and used in accordance with the instruction manual, it may cause interference with radio and television reception. It has been tested and found to comply with the limits for a Class B computing device pertinent to subpart J of part 15 of FCC rules, which are designed to provide reasonable protection against such interference in a residential installation. If this equipment does cause interference, the user is encouraged to try to correct the interference by one or more of the following measures:

1. Reorient the receiving antenna.
2. Relocate the receiver with respect to the device. Turning the receiver slightly may eliminate the interference. If not, move the receiver to different locations within the room.

## LOCATION AND MOUNTING

### Location

Choose a location for the W7100 Discharge Air Controller that is not exposed to the weather, and where controls, connections and the diagnostic analyzer socket are accessible. Locate the 24 Vac power supply as close to the W7100 as possible.

### Mounting

Mount the controller with four No. 8 screws through the mounting holes in the base. See Fig. 1.

Mount the C7100A Sensor in the DA air duct with four No. 8 screws through the mounting flange.

Mount other control system components according to instructions packed with the individual units.

## WIRING



## CAUTION

Wiring routed to the W7100A-E Discharge Air Controller inputs/outputs from sensors, transducers, switches, or valve and damper actuators should not be bundled with or run in wire track or conduit with any line or low voltage AC power lines or switched AC lines. The 24 Vac supply to the W7100A-E must not be connected to earth ground and the supply lines should not be bundled with line voltage lines. Wiring should be kept at least one foot away from large inductive loads such as motors, line starters, lighting ballasts and large power distribution panels. Failure to follow these wiring practices may introduce electrical interference (noise) that can cause erratic system operation. Shielded cable may be required in some installations.

**IMPORTANT:** *All components of the W7100 System must be powered from a separate 24 Vac transformer. Make sure that the 24 Vac power supply used for these components is properly sized for the respective components within the W7100 System. If adequate power is not provided to the system, erratic control or component damage could result.*

**NOTE:** If shielded cable is used for sensor wiring, ground one end only of the shield.

Disconnect power supply before making connections to prevent electrical shock or equipment damage. All wiring must comply with applicable codes and ordinances. Refer to Figs. 3 through 11 for typical hookup diagrams.

W7100A-E wiring and hookup diagrams are shown in the W7100 Operation and Application section as follows:

- a. The W7100A (six-stage cooling) is shown in Fig. 4; with economizer in Fig 5.
- b. Fig. 6 shows discharge air temperature control operation.

- b. The W7100B (six-stage heating) is shown in Fig. 7.
- c. The W7100C (four cool/two heat stages) with changeover is shown in Fig. 8.
- d. Reset for W7100A-C (from space or outdoor air) is shown in Figs. 9, 10, and 11.
- e. The W7100D (modulating heat/cool) is shown in Fig. 12.
- f. The W7100E (modulating heat/4 stage cooling) is shown in Fig. 13.

Fig. 3— Typical VAV system.

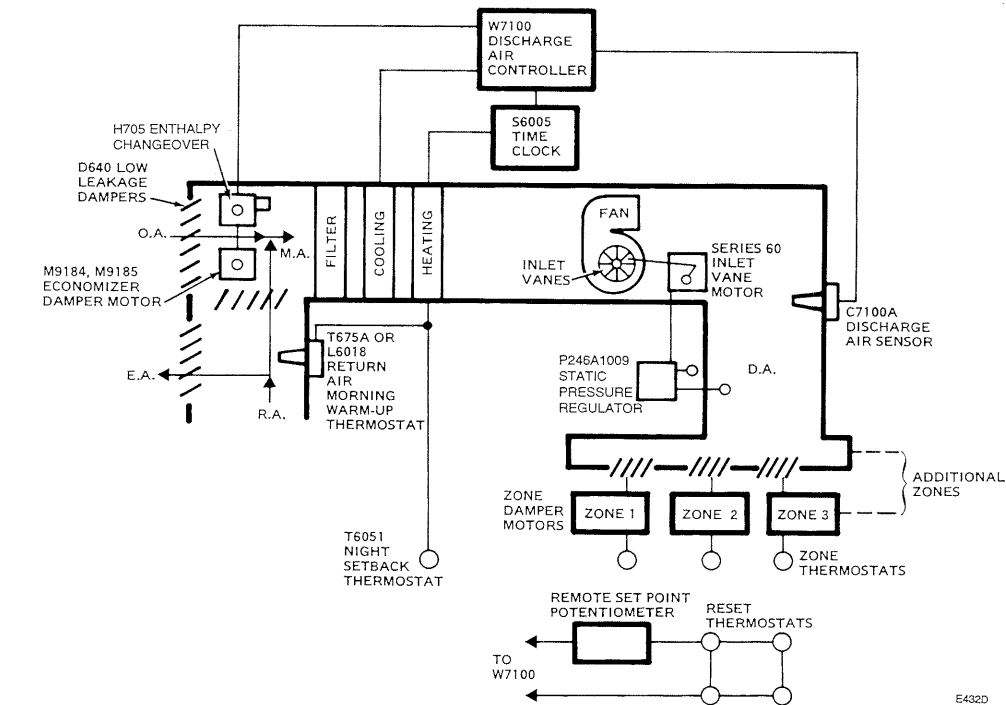

E432D

**Fig. 4—Connections in W7100A six-stage cooling system with DA sensor, DA reset sensor, remote DA setpoint and reset potentiometer (without economizer).**

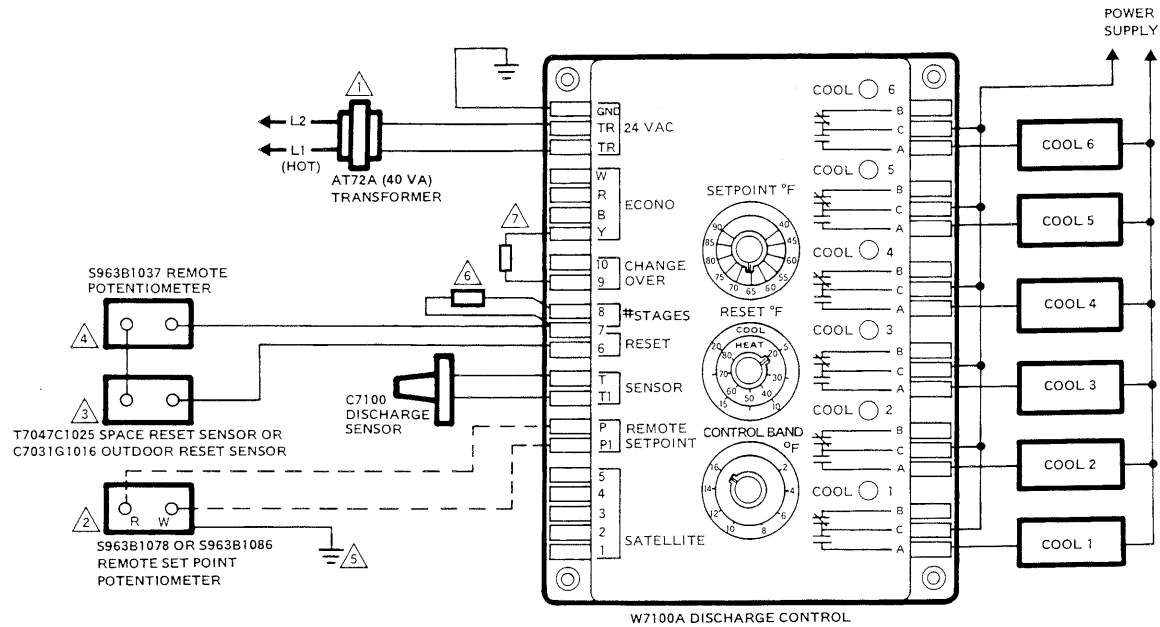

- ⚠ POWER SUPPLY. PROVIDE DISCONNECT MEANS AND OVERLOAD PROTECTION AS REQUIRED.
- ⚠ WHEN REMOTE SETPOINT NOT USED, JUMPER TERMINALS P AND P1. WHEN USED, TURN SETPOINT KNOB ON W7100 TO MINIMUM POSITION. USE OF THE S963B1086 WILL CHANGE SETPOINT RANGE TO 40° F TO 140° F.
- ⚠ WHEN RESET NOT USED, JUMPER TERMINALS 6 AND 7.
- ⚠ USE ONLY WITH SPACE RESET SENSOR. CONNECT IN SERIES AS SHOWN.
- ⚠ GROUND CASE OF REMOTE SETPOINT POTENTIOMETER TO PREVENT PROBLEMS DUE TO STATIC ELECTRICITY.
- ⚠ FACTORY INSTALLED 600 OHM RESISTOR JUMPER FOR 6 STAGE OPERATION. CHANGE TO CORRECT VALUE AS NEEDED.
- ⚠ JUMPER TERMINALS Y AND 9 WITH A 510 OHM 1/4 WATT, 5 PERCENT RESISTOR (CONTAINED IN 4074EFV BAG ASSEMBLY) TO ELIMINATE ECONOMIZER DELAYS. E3285

**Fig. 5—Connections in W7100A six-stage cooling system with economizer, DA sensor, DA reset sensor, remote DA setpoint and reset potentiometer.**

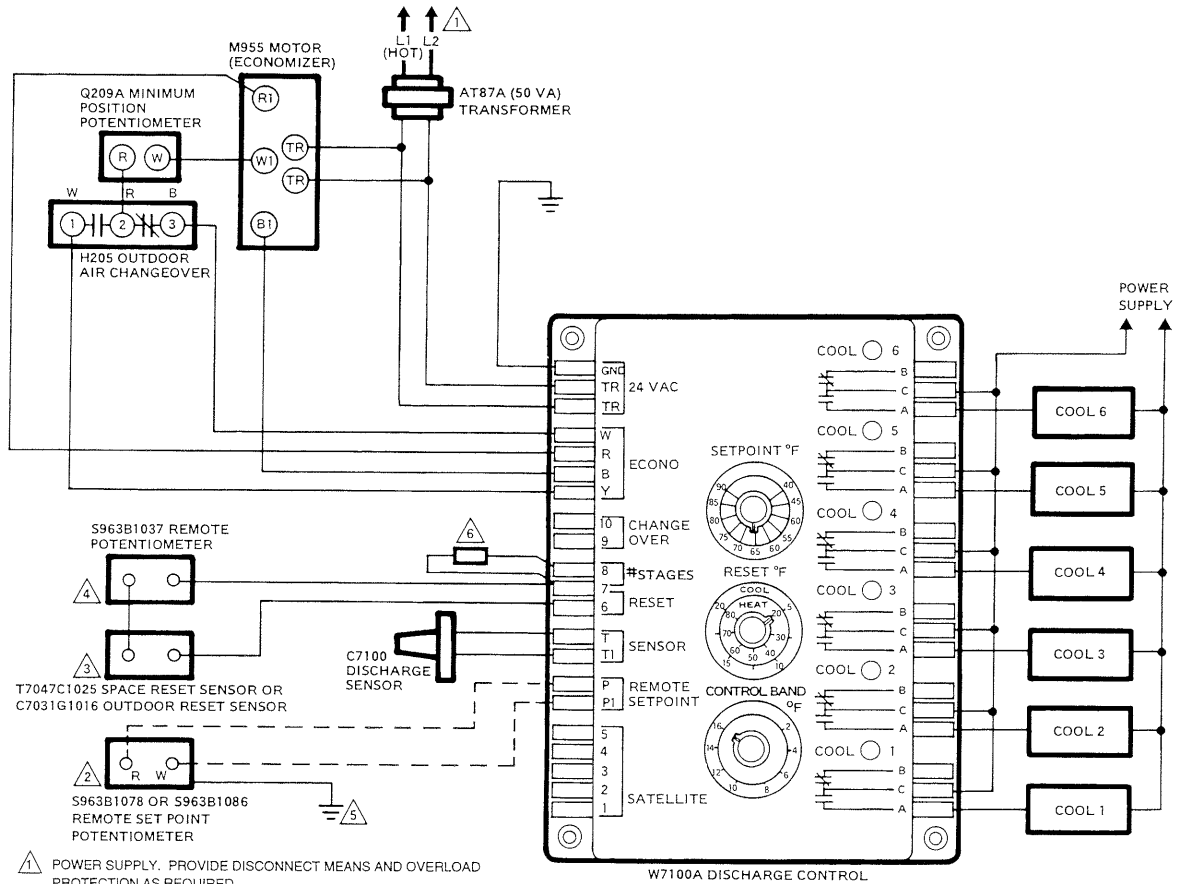

- ⚠ POWER SUPPLY. PROVIDE DISCONNECT MEANS AND OVERLOAD PROTECTION AS REQUIRED.
- ⚠ WHEN REMOTE SETPOINT NOT USED, JUMPER TERMINALS P AND P1. WHEN USED, TURN SETPOINT KNOB ON W7100 TO MINIMUM POSITION. USE OF THE S963B1086 WILL CHANGE SETPOINT RANGE TO 40° F TO 140°F.
- ⚠ WHEN RESET NOT USED, JUMPER TERMINALS 6 AND 7.
- ⚠ USE ONLY WITH SPACE RESET SENSOR. CONNECT IN SERIES AS SHOWN.
- ⚠ GROUND CASE OF REMOTE SETPOINT POTENTIOMETER TO PREVENT PROBLEMS DUE TO STATIC ELECTRICITY.
- ⚠ FACTORY INSTALLED 600 OHM RESISTOR JUMPER FOR 6 STAGE OPERATION. CHANGE TO CORRECT VALUE AS NEEDED.

E325B



Fig. 6—W7100 discharge air temperature control operation.

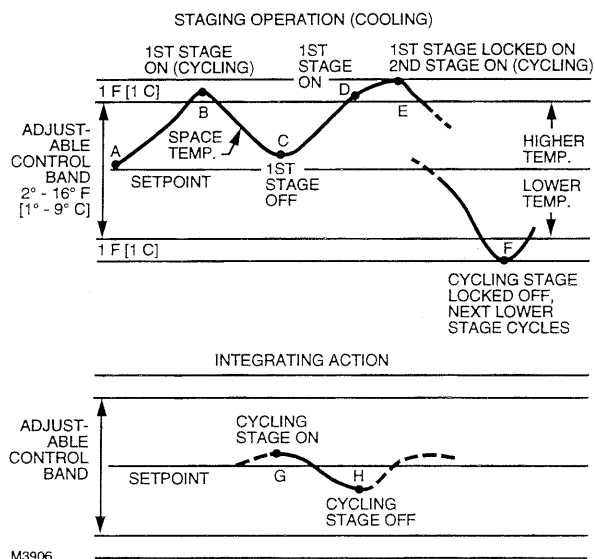
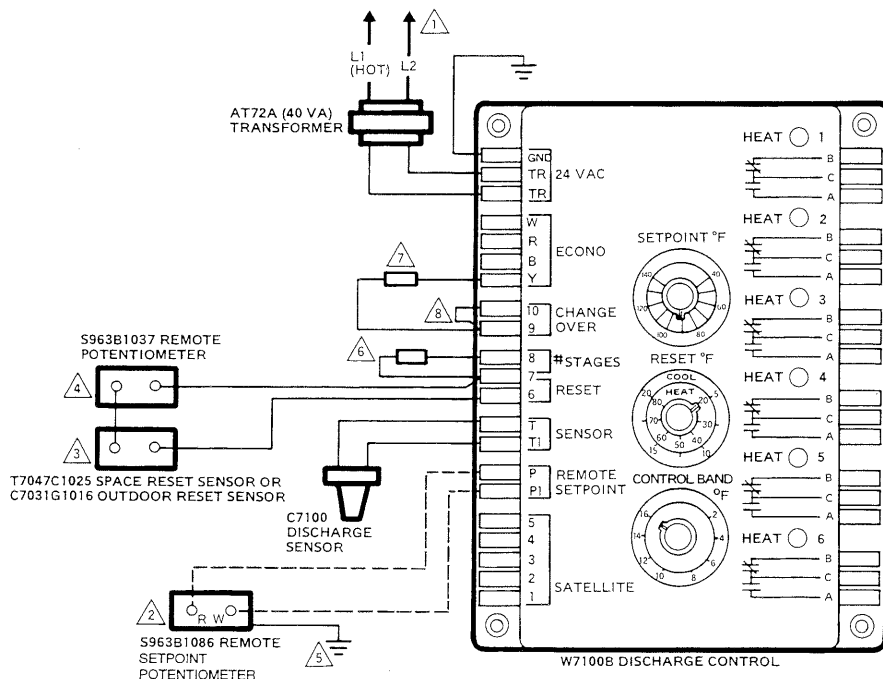
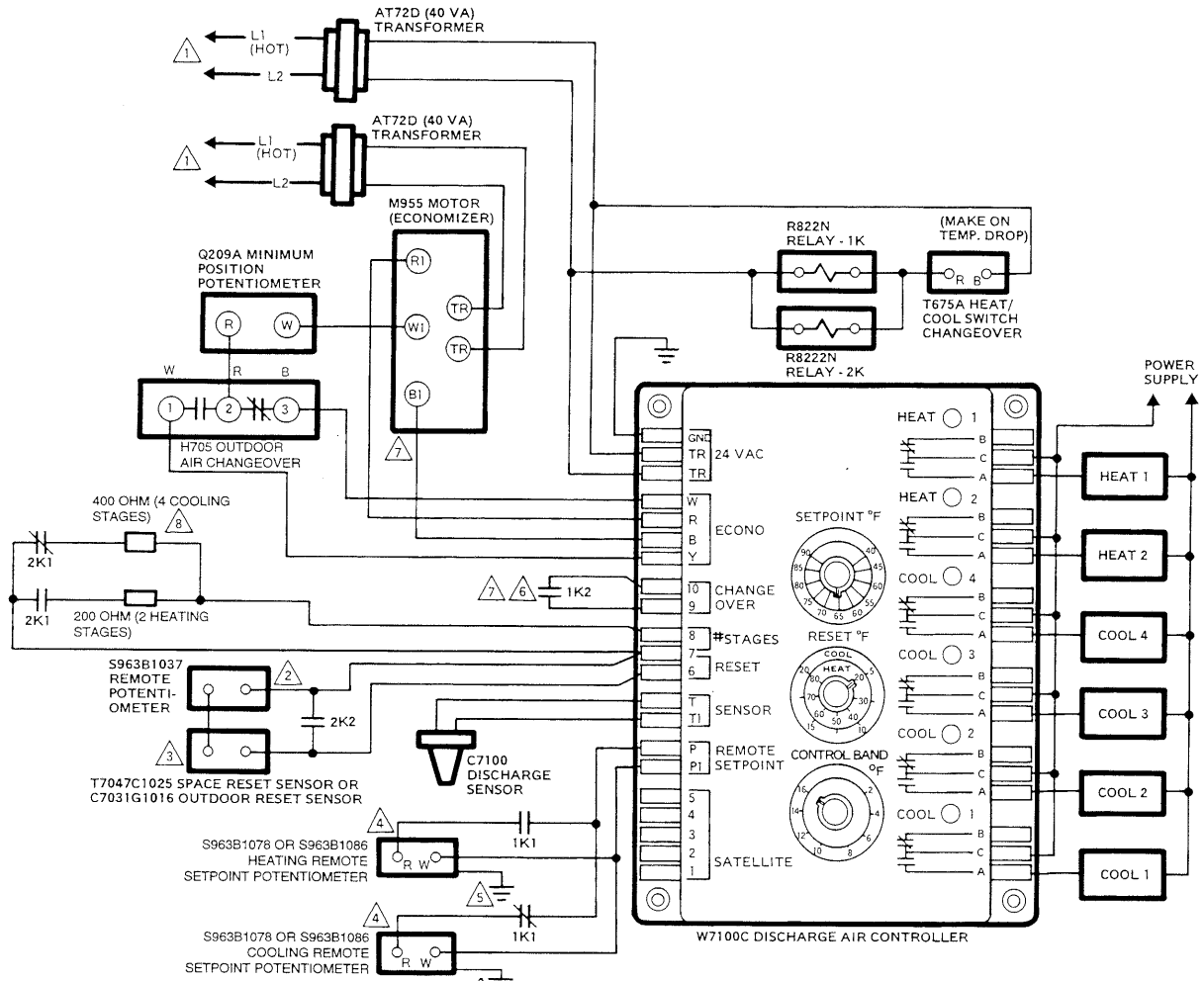

Fig. 7—Connections in W7100B six-stage heating system with DA sensor, DA reset sensor, remote DA setpoint and reset potentiometer.



- ⚠ POWER SUPPLY. PROVIDE DISCONNECT MEANS AND OVERLOAD PROTECTION AS REQUIRED.
  - ⚠ WHEN REMOTE SETPOINT NOT USED, JUMPER TERMINALS P AND P1.
  - ⚠ WHEN RESET NOT USED, JUMPER TERMINALS 6 AND 7.
  - ⚠ USE ONLY WITH SPACE RESET SENSOR. CONNECT IN SERIES AS SHOWN.
  - ⚠ GROUND CASE OF REMOTE SETPOINT POTENTIOMETER TO PREVENT PROBLEMS DUE TO STATIC ELECTRICITY.
  - ⚠ FACTORY INSTALLED 600 OHM RESISTOR JUMPER FOR 6 STAGE OPERATION. CHANGE TO CORRECT VALUE AS NEEDED.
  - ⚠ WHEN ECONOMIZER IS NOT USED, JUMPER TERMINALS Y AND 9 WITH A 510 OHM 1/4 WATT 5 PERCENT RESISTOR CONTAINED IN 4074EFV BAG ASSEMBLY.
  - ⚠ JUMPER TERMINALS 9 AND 10 TO CHANGE OVER TO HEATING (LOCKS OUT COOLING). WHEN USED WITH W7101 SATELLITE, TERMINALS 9 AND 10 ARE OPEN FOR COOLING AND SHORTED FOR HEATING.
- E576A

Fig. 8—Connections in W7100C two-stage heating/four-stage cooling system with changeover.



- ⚠ POWER SUPPLY. PROVIDE PROTECTION MEANS.
- ⚠ USE ONLY WITH SPACE RESET SENSOR. CONNECT IN SERIES AS SHOWN.
- ⚠ WHEN RESET NOT USED, JUMPER TERMINALS 6 AND 7.
- ⚠ SET HEAT AND COOL DISCHARGE SETPOINTS USING REMOTE SETPOINT POTENTIOMETERS. TURN SETPOINT KNOB ON W7100 TO MINIMUM POSITION. USE OF THE S963B1086 WILL CHANGE SETPOINT RANGE TO 40° F TO 140° F.
- ⚠ GROUND CASE OF REMOTE SETPOINT POTENTIOMETER TO PREVENT PROBLEMS DUE TO STATIC ELECTRICITY.
- ⚠ WHEN CHANGEOVER TERMINALS 9 AND 10 USED ON HEAT/COOL MODELS, JUMPER 9-10 TO CHANGE OVER TO HEATING (LOCKS OUT COOLING WHEN JUMPERED).
- ⚠ WHEN ECONOMIZER IS NOT USED, JUMPER TERMINALS Y AND 9. WITH A 510 OHM, 1/4 WATT, 5 PERCENT RESISTOR CONTAINED IN 4074EFV BAG ASSEMBLY.
- ⚠ REMOVE FACTORY INSTALLED 400 OHM RESISTOR JUMPER AND RECONNECT FOR COOLING-ONLY MODE, 4-STAGE OPERATION (CHANGE VALUE FOR OTHER NUMBER OF STAGES). FOR 2 STAGES IN HEATING MODE, USE 200 OHM 1/8 WATT RESISTOR FOR BEST OPERATION.

E568A

Fig. 9—Reset from space thermostat wiring.

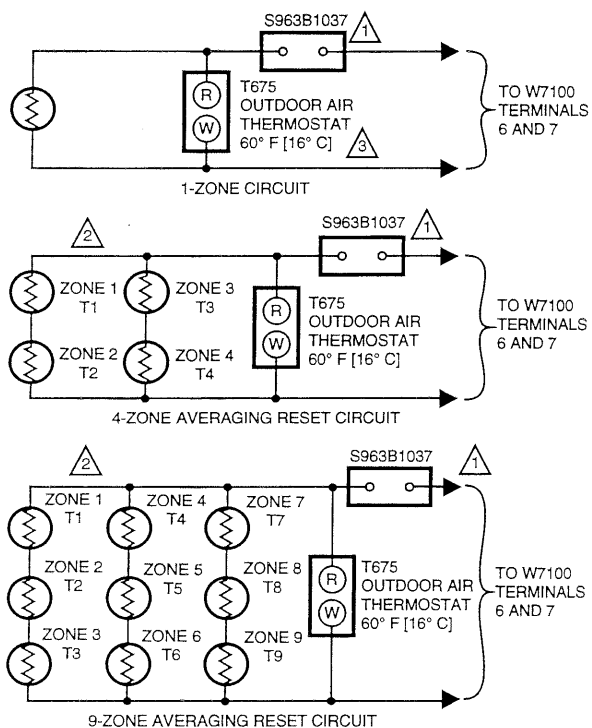

- △1 S963B1037 REMOTE SETPOINT POTENTIOMETER REQUIRED TO PERMIT ADJUSTMENT OF RESET CONTROL POINT. (USE ONLY WITH SPACE SENSORS. DO NOT USE WITH OUTDOOR SENSORS.)
  - △2 ALL THERMOSTATS ARE T7047C1025 TYPE WIRED IN SERIES-PARALLEL CONNECTION.
  - △3 LOCK OUT RESET UNDER HIGH HUMIDITY CONDITIONS, SET AT 60° F [16° C].
- M3962

Fig. 10—W7100 space reset algorithm.

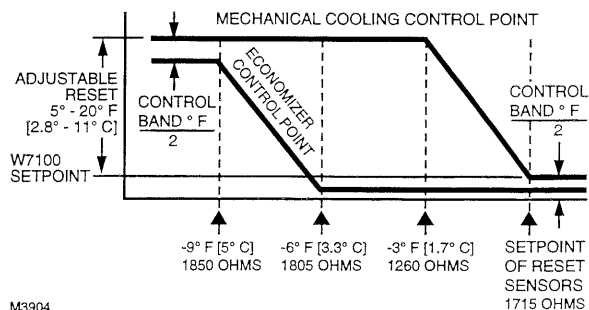
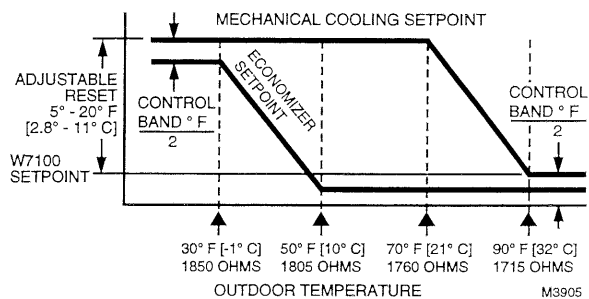
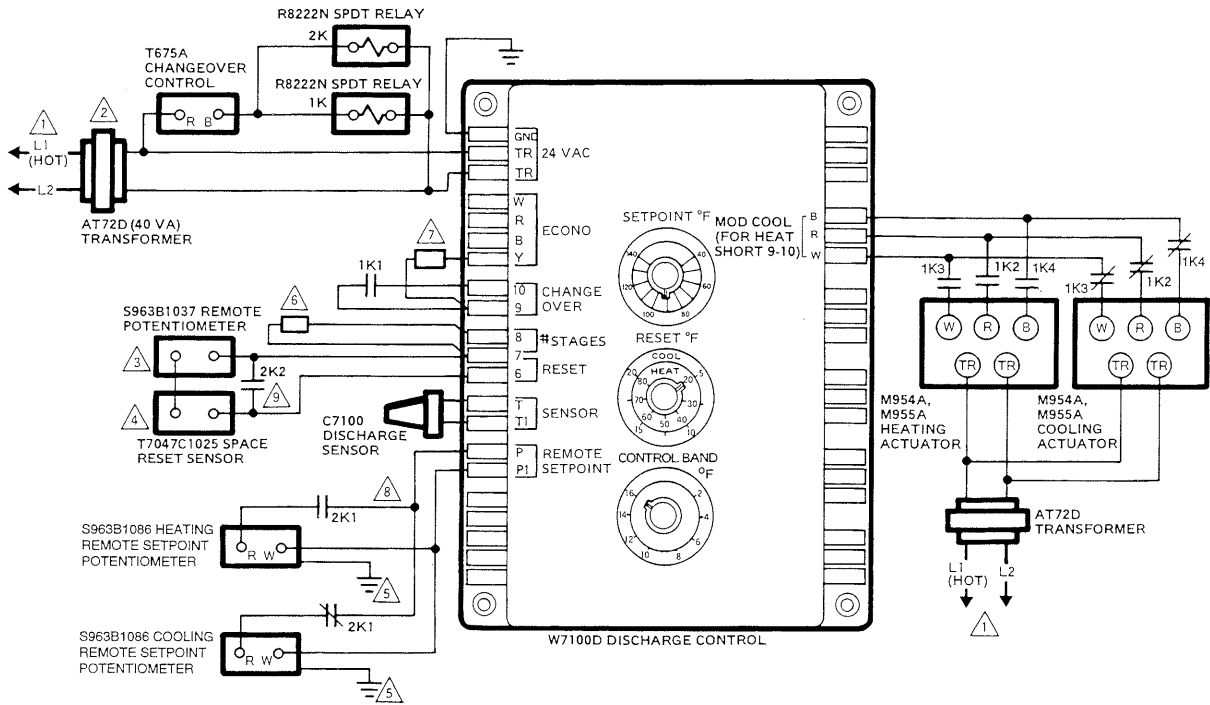

Fig. 11—Outdoor reset schedule using C7031G1016.



**Fig. 12—Connections in W7100D modulating heating/cooling system with changeover, DA sensor, DA reset sensor, remote DA setpoint and reset potentiometer.**



- ⚠ POWER SUPPLY. PROVIDE DISCONNECT MEANS AND OVERLOAD PROTECTION AS REQUIRED.
- ⚠ USE SAME TRANSFORMER FOR W7101 SATELLITE (IF USED) AS FOR W7100. SIZE TRANSFORMER AS NEEDED.
- ⚠ USE ONLY WITH SPACE RESET SENSOR. CONNECT IN SERIES AS SHOWN.
- ⚠ WHEN RESET NOT USED, JUMPER TERMINALS 6 AND 7.
- ⚠ GROUND CASE OF REMOTE SETPOINT POTENTIOMETER TO PREVENT PROBLEMS DUE TO STATIC ELECTRICITY.
- ⚠ FACTORY INSTALLED 100 OHM RESISTOR JUMPER FOR NO. STAGES OF OPERATION.
- ⚠ WHEN ECONOMIZER IS NOT USED, JUMPER TERMINALS Y AND 9 WITH A 510 OHM 1/4 WATT 5 PERCENT RESISTOR CONTAINED IN 4074EFV BAG ASSEMBLY.
- ⚠ WHEN REMOTE SETPOINT NOT USED, JUMPER TERMINALS P AND P1. WHEN USED, TURN SETPOINT KNOB ON W7100 TO MINIMUM POSITION.
- ⚠ RESET DISABLED FOR HEATING.

E577A

Fig. 13—Connections in W7100E modulating heat/four-stage cooling system with economizer, DA sensor, DA reset sensor, remote DA setpoint and reset potentiometer.

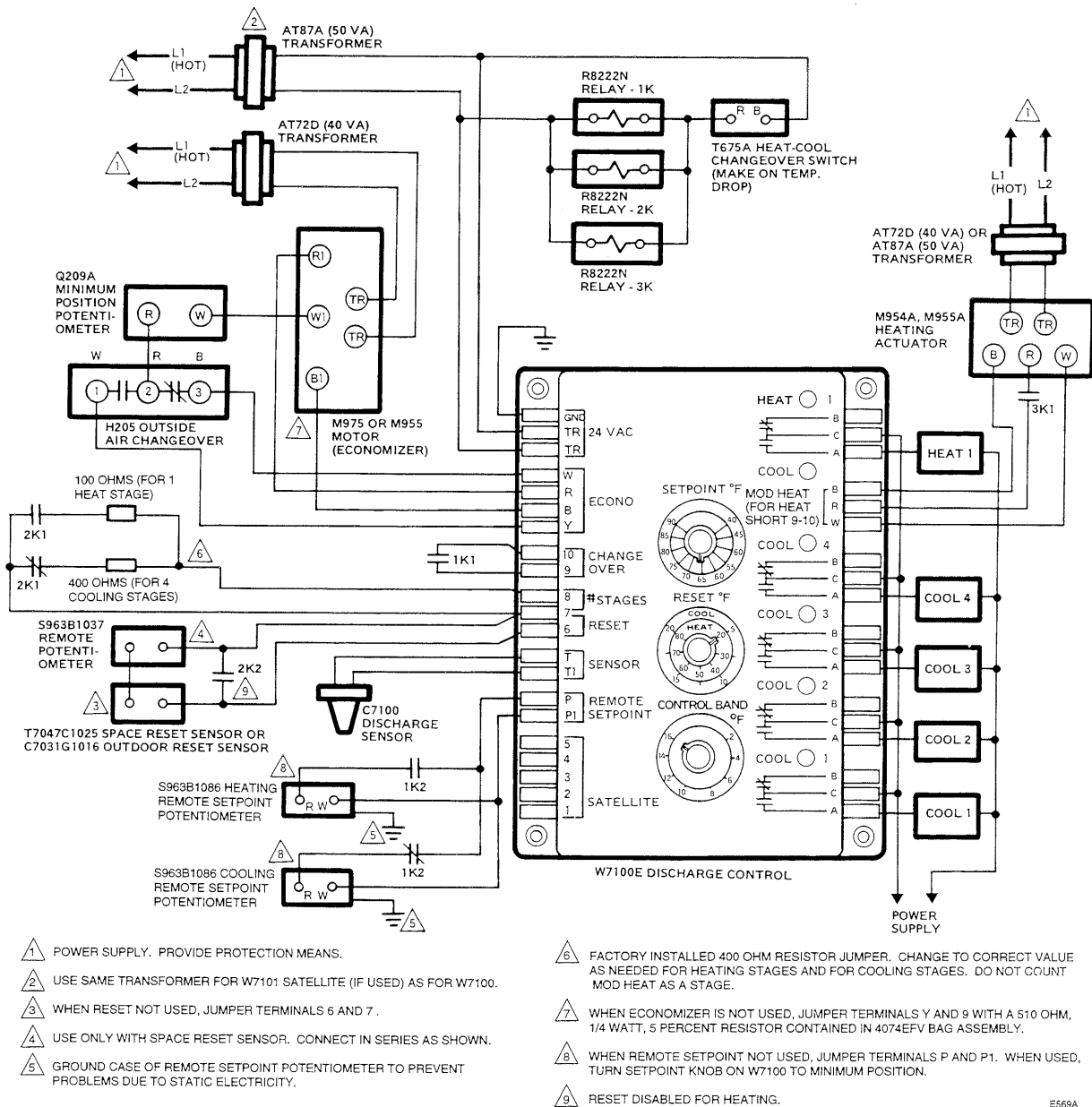

Special W7100 applications and wiring are shown in the W7100 Special Applications Section as follows:

- a. Use of the W7101A Sequencer to connect an additional six stages of heating/cooling is shown in Fig. 14.
- b. Night setback and morning warmup operation is shown in Fig 15.

c. Pneumatic interfacing with MicroniK® controls is shown in Fig. 16.

d. Space resets from pneumatic space thermostats with L91B1035 Pressuretrol® controller is shown in Fig. 16.

**Fig. 14—Connections in W7100 heating/cooling system (W7100A shown) with W7101A Satellite Sequencer, economizer, DA sensor, DA reset sensor, remote DA setpoint and reset potentiometer.**

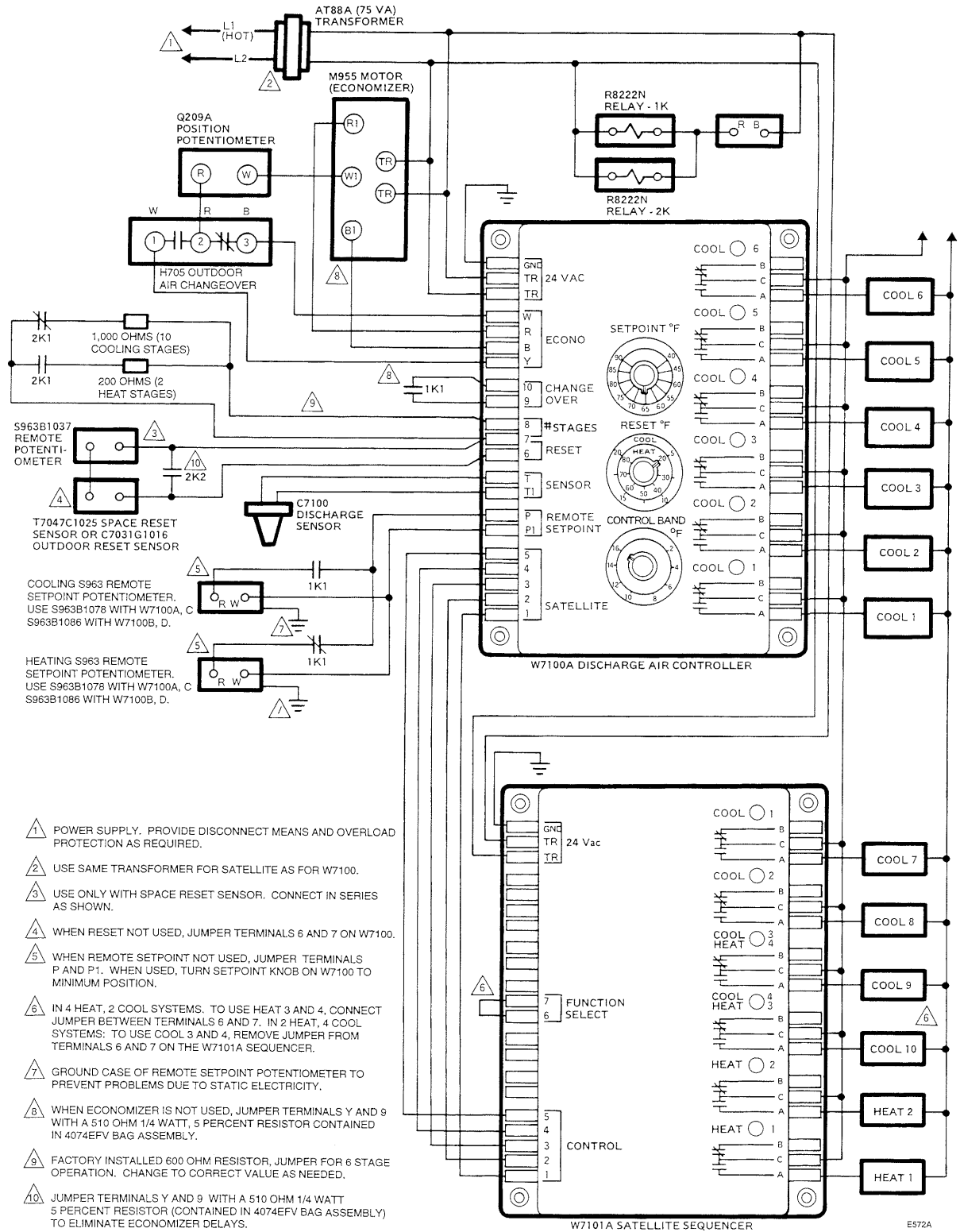

Fig. 15—W7100 heating/cool system (W7100C shown) with economizer, night setback and morning warmup.

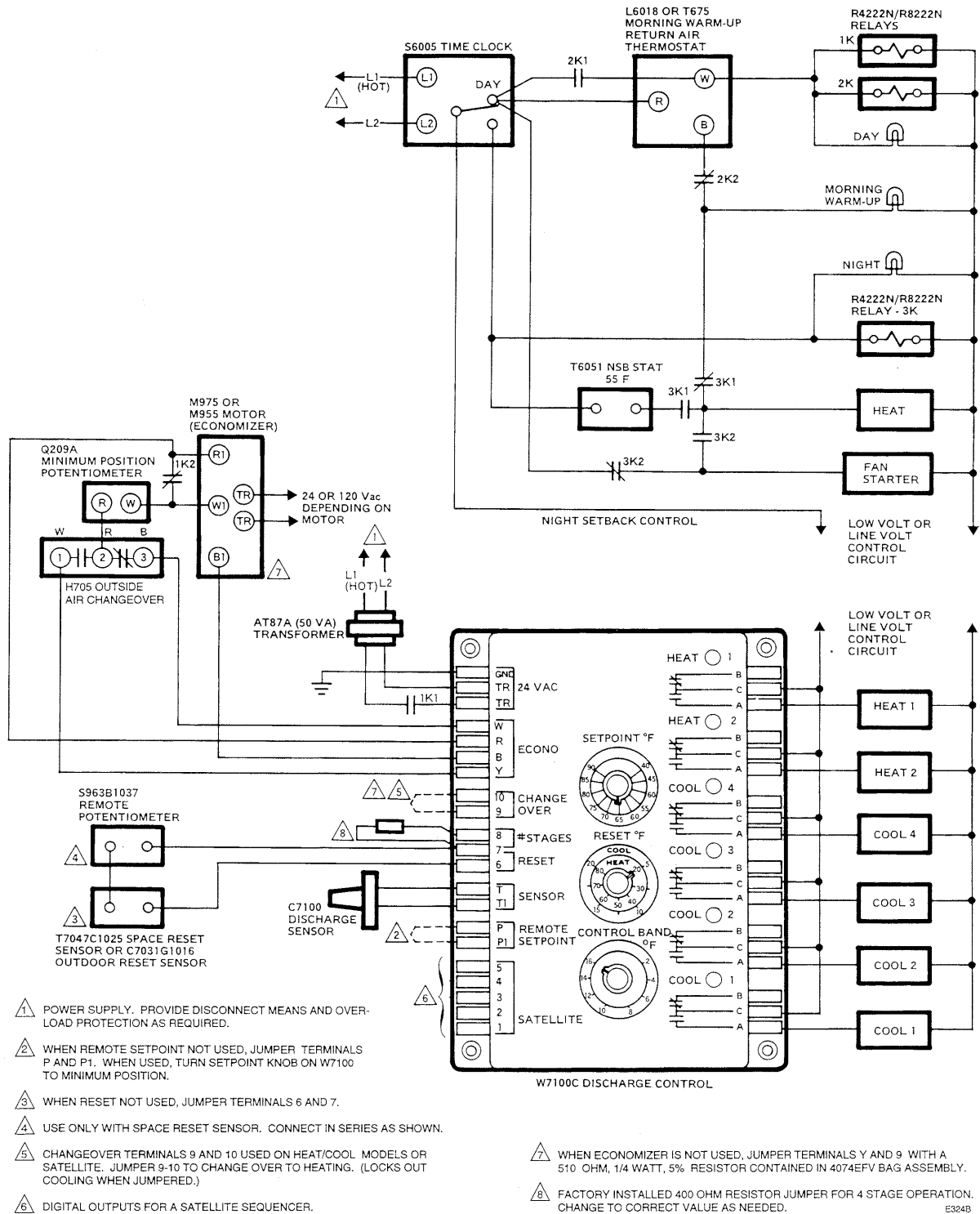
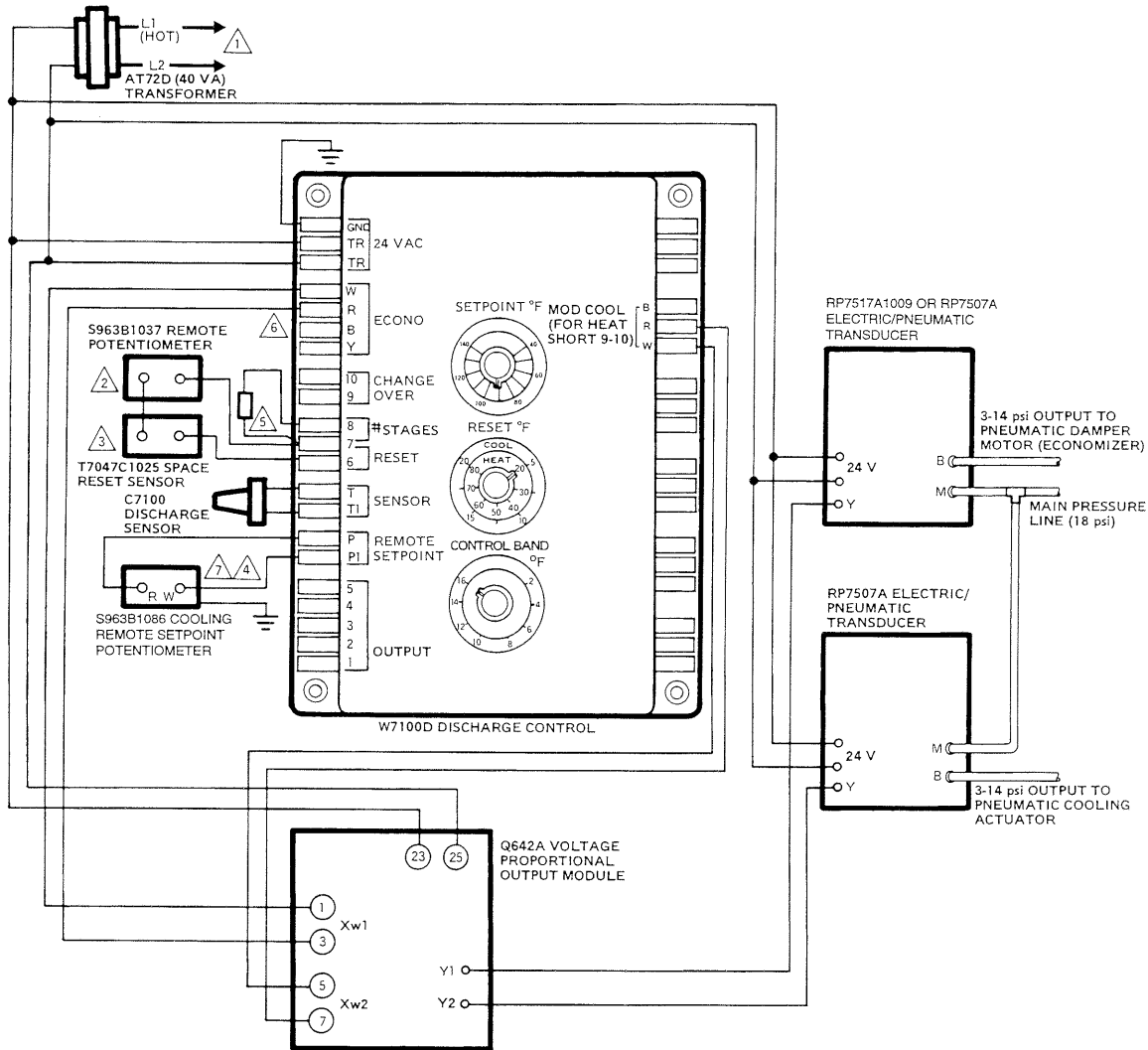

Fig. 16—Connections in W7100D pneumatic cooling only system with an economizer.



- ⚠ POWER SUPPLY. PROVIDE DISCONNECT MEANS AND OVERLOAD PROTECTION AS REQUIRED.
- ⚠ USE ONLY WITH SPACE RESET SENSOR. CONNECT IN SERIES AS SHOWN.
- ⚠ WHEN RESET NOT USED, JUMPER TERMINALS 6 AND 7.
- ⚠ GROUND CASE OF REMOTE SETPOINT POTENTIOMETER TO PREVENT PROBLEMS DUE TO STATIC ELECTRICITY.
- ⚠ CHANGE FACTORY INSTALLED 1000 OHM RESISTOR JUMPER TO 100 OHM FOR 2-STAGE COOLING OPERATION.
- ⚠ WHEN ECONOMIZER IS NOT USED, JUMPER TERMINAL Y AND 9 WITH A 510 OHM RESISTOR.
- ⚠ WHEN REMOTE SETPOINT NOT USED, JUMPER TERMINALS P AND P1. WHEN USED, TURN SETPOINT KNOB ON W7100 TO MINIMUM POSITION. E575A

### CHANGING NUMBER OF CONTROLLED STAGES

A fixed resistor is installed across the Number of Stages input (terminals 7 and 8). The resistor value tells the W7100 how many stages of heating and cooling are to be controlled. This affects the control behavior and determines how many stages the W7100 will turn on and off.

A resistor is initially installed by the factory on terminals 7 and 8 (see Table 2). This corresponds to the value for controlling the maximum number of heating or cooling stages on the W7100. If the system being installed has more

or fewer stages of heating or cooling, this resistor must be changed to the value shown in Table 2. The new value will represent the actual number of heating/cooling stages operating under control of the W7100. This includes any stages on a W7101A Sequencer connected to the W7100 control (see Connecting Additional Stages section).

In heat/cool staged systems, the heat/cool changeover device should also switch in the proper resistance for the number of heating and cooling stages for best system performance.



TABLE 2—INPUT RESISTANCE FOR NUMBER OF CONTROLLED STAGES.

Total No. of Heating or Cooling Stages	Resistance in Ohms ± 1% Across Terminals 7 and 8 <sup>a</sup>	4074EFV Bag Assembly Wire Colors <sup>b</sup>	Factory Installed on Model Number
1 (W7100 only)	100	Blue	W7100D
2 (W7100 only)	200	Red	—
3 (W7100 only)	301	Yellow	—
4 (W7100 only)	402	Brown	W7100C,E
5 (W7100 only)	499	Green	—
6 (W7100 only)	600	—	W7100A,B
7 (W7100 and W7101A)	698	Orange	—
8 (W7100 and W7101A)	806	White	—
9 (W7100 and W7101A)	909	Violet	—
10 (W7100 and W7101A)	1000	Black	—

<sup>a</sup> Use 1/8W resistors. For heating/cooling systems, use relay contacts in the changeover circuit to switch between the correct resistor value for number of heating or number of cooling stages. Resistor values shown are standard values.

<sup>b</sup> 4074EFV Bag Assembly available separately. Bag assembly also contains a 510 ohm 1/8W resistor (tan wiring) for systems without economizer.

### CONNECTING ADDITIONAL STAGES

Control of up to six additional stages of on-off heating or cooling can be provided by adding a W7101A Satellite Sequencer to the W7100 System. The W7101A can provide either 2-heat/4-cool, or 4-heat/two cool stages, selected by a jumper at terminals 6 and 7 on the W7101A.

The fixed resistor value across the W7100 terminals 7 and 8 (see Table 2) must agree with the combined number of heating/cooling stages controlled by the W7100 and W7101A.

## Operation

### VARIABLE AIR VOLUME SYSTEM STAGED OPERATION

Variable air volume (VAV) systems operate on the principle that space temperature can be maintained by varying the volume of constant temperature air delivered to the space. In a true VAV system, as the space load decreases, air delivered to the space is pinched off. With less air required, both the fan and compressor require less horsepower, and operating costs are reduced.

VAV systems generally provide cooling only; however, the central air handler may include optional heating or night setback, morning warmup or cold weather operation when a high percentage of outdoor air is brought into the building. Heating for the building is often provided by a separate hydronic perimeter system.

A typical cooling-only VAV system is shown in Fig. 4; with an economizer in Fig. 5. During the occupied mode, the W7100 maintains DA temperature by first modulating the economizer open—then, if necessary, by activating stages of mechanical cooling. Mechanical cooling is needed only when the economizer alone cannot maintain

the DA temperature. The heating only section is shown in Fig. 7. A heating/cooling system is shown in Figs. 8, 12, and 13. A heating/cooling system with night setback and morning warmup options is shown in Fig. 14. A night setback thermostat will cycle the system in a heating mode to prevent the building from becoming too cold.

### FAN CONTROL

The W7100 does not interface with the system fan to regulate the air volume in pinch-off VAV systems. Some control alternatives for different types of system fans are as follows:

1. Forward-curve fan: no static pressure regulation.
2. Discharge dampers: controlled by a static pressure regulator.
3. Inlet vanes used with airfoil fans: controlled by a static pressure regulator.
4. Blower motor speed: controlled by a static pressure regulator.
5. Variable pitch axial fan: controlled by a static pressure regulator.

The type of fan control selected depends partly on the ratio of minimum air volume to maximum air volume expected for a given system, and partly on economic factors. The Honeywell P246A Static Pressure Regulator is recommended for static pressure control.

### ECONOMIZER CONTROL

Economizer operation (Fig. 5) is influenced by a two-fold algorithm (program) in the W7100. The first algorithm offsets the economizer an amount equal to two control band degrees F below the setting of the setpoint knob. As an example, with the W7100 setpoint knob at 60° F [16° C], and the control band setting of 4° F [2.2° C], the economizer will actually control the discharge air at 2° F [1° C] below 60° F [16° C], or 58° F [15° C], keeping the discharge air temperature slightly on the cold side, forcing the system fan to throttle back, reducing fan horsepower and saving energy.

The second algorithm causes economizer operating speed to increase as the DA temperature deviates further from the control point, and to slow down as DA temperature approaches the control point. When the DA temperature is within plus or minus 1.5° F [0.8° C] of the control point, the economizer motor will stop. This particular deadband was chosen because of the play inherent in the linkages and ball joints, and because of the modulating characteristics of oversized and nonlinear dampers.

### DISCHARGE TEMPERATURE CONTROL OPERATION

The W7100 uses an integrating control band concept to provide close, stable temperature control in discharge air temperature control systems. The control band concept matches required operating capacity to building load while integral control action minimizes offset from the control setpoint.

The control band setting is centered on the discharge air temperature setpoint (Fig. 6). The control band setting is adjustable from 2° F to 16° F [1° C to 9° C]. This adjustment is used to stabilize system operation. A second level of heat/cool control spaced 1° F [1° C] outside the control band is used to select the number of stages that are allowed to operate.

Following is a description of how staging operates, using cooling with an economizer as an example:

Beginning at point A in Fig. 6, the economizer has already modulated to its fully open position. As building load increases, the discharge temperature floats to the upper limit of the control band at point B. At this time, the first stage of cooling energizes for the minimum period of four minutes. This brings the discharge air temperature within the control band region.

After four minutes, the first stage turns off (point C) and the temperature begins to rise again. At least four additional minutes have elapsed at point D, and the first stage turns on again. This time, however, the building load has increased until the space temperature rises to the outer limit at point E. At this point (E), the first stage locks on and the second stage cycles on, pulling the discharge air temperature back within the control band region.

This process continues through all connected stages. The highest numbered active stage is always the cycling stage. In this way the operating equipment is always matched to the required capacity as closely as possible.

To turn off the equipment, the process is reversed. When the discharge temperature is pulled down to the lower outer limit at point F, the cycling stage is locked off and the next lower stage begins to cycle (becomes active).

The integrating action of the control is shown in Fig. 6. When the discharge temperature floats within the control band (points G and H), the active stage is energized periodically to pull the discharge temperature to the control setpoint. This integrating action is used to maintain accurate control of discharge air temperature.

### POWER FAILURE

When power fails, the W7100 shuts off all stages of mechanical cooling. When power resumes, the economizer will first be modulated open, if enthalpy of the outside air is suitable. Once the economizer is open, mechanical cooling is sequenced back on with a minimum of four minutes between succeeding stages. If outdoor air enthalpy is not suitable, economizer modulation is bypassed, allowing mechanical cooling to begin sequencing after four minutes, with a minimum of four minutes between stages.

### HEATING MODE OF OPERATION

The W7100B,C,D and E—or the W7100A in conjunction with a W7100 Sequencer—can be used to provide control of heating the discharge air in VAV systems. See Fig. 6 for W7100B heat only, and Figs. 7, 11, 12 and 13 for typical heat/cool systems.

The heating mode is sometimes used in systems that bring in a high percentage of outdoor air during cold weather. If an application requires more than 25 percent outdoor air, heat may have to be added to warm up the discharge air to 55° F

or 60° F [13° C or 16° C]. To change the W7100 into a heating mode, the changeover input terminals 9 and 10 must be jumpered.

When using the W7100 in a heating mode during cold weather to warm the mixed air temperature up to 55° F or 60° F [13° C or 16° C], jumper reset terminals 6 and 7 (shown in Figs. 7 and 13) to prevent the reset sensors from raising the discharge temperature to the point where the terminal boxes drive fully open.

If the W7100 is used in a VAV heating application, use reset to raise the discharge temperature as the building temperature falls, as shown in Fig. 7. An example would be a VAV perimeter or reheat system where the W7100 would be used to control a separate heating-only air handler. The heating air handler would supply air to perimeter heating-only terminals, or to reheat terminals.

The heating and cooling reset schedules are similar. As the temperature drops below the setpoint of the reset sensors, the discharge air temperature rises. For reset adjustments, note that the inner (heating) reset scale is four times the outer (cooling) scale.

Fig. 17—W7100 Discharge Air Temperature Control operation.

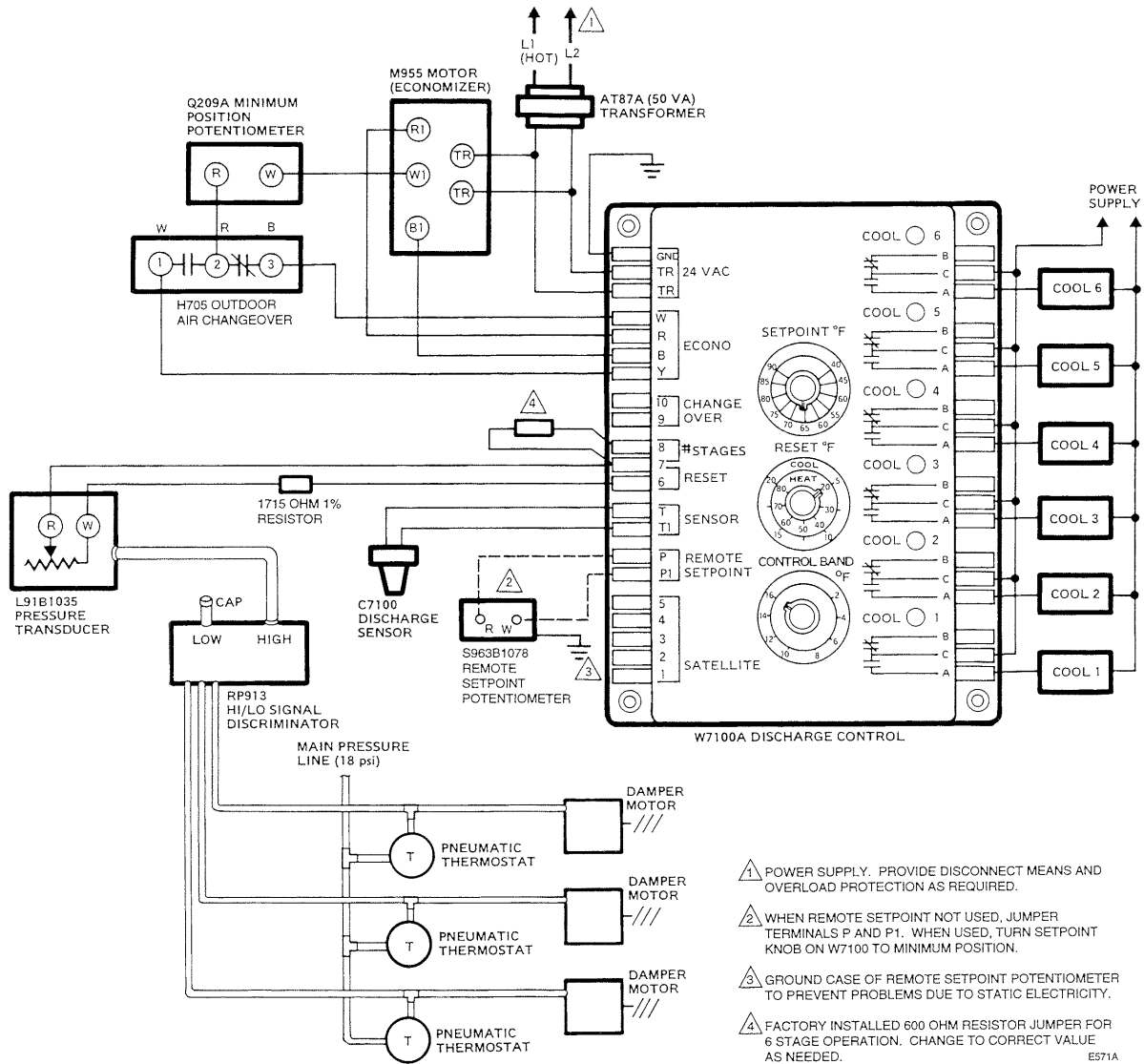

### HEAT/COOL CHANGEOVER OPERATION

Connect heat/cool changeover switch to terminals 9 and 10 as shown in Figs. 8, 12 and 13. On all W7100 models, the changeover switch opens for cooling and closes for heating when there is a call for heat. In heat/cool systems with a W7100 for six stages of cooling and a W7101 for the heating stages (see Fig. 13) the changeover switch again turns off cooling, but heat stages are brought on only through the satellite when there is a call for heat.

### RESET CONTROL WITH VAV SYSTEMS

#### Discharge Air Reset

Reset is used to prevent overcooling or overheating of the building when there are one or more zones of abnormal demand. The discharge temperature is reset upward as the space temperature drops, reducing cooling capacity

required to satisfy building demand. DA reset can be controlled from the space or from outdoor sensors.

To provide DA reset from the space, install a T7047C1025 Thermostat in the space and connect it in series with an S963B1037 Remote Setpoint Potentiometer to terminals 6 and 7 on the W7100 as shown in Fig. 5. To provide reset based on average zone temperature, install reset thermostats in selected zones and connect them in series-parallel (two groups of two, three groups of three, etc.) as shown in Fig. 9. This type of connection ensures correct total sensor resistance at the W7100 reset terminals. The remote setpoint potentiometer—shown connected in series with the sensor—is needed to permit adjustment of the DA reset control point. In systems where pneumatic zone dampers are used, the circuit shown in Fig. 16 may be used to provide reset from the pneumatic thermostats.

To provide DA reset from outdoor air, connect a C7031G1016 Sensor to the W7100 reset terminals 6 and 7 (Fig. 5).

### Reset From Space Temperature

A VAV system can be made more economical by resetting the discharge air temperature from the average building temperature. This type of reset is most effective in buildings where there is not a wide diversity of cooling loads between zones. Typical examples are office buildings, department stores, discount stores, single-story buildings, and installations where minimum-volume terminal boxes are used.

VAV systems that discharge constant temperature air tend to overcool a building during cold weather for three reasons. One reason is that the air distribution system may be oversized. A second reason is that buildings with minimum volume boxes may not be able to pinch off enough air to match the decreasing load on the building. A third reason for overcooling is that during cold weather the VAV system economizer may be exhausting BTUs from the building, placing a greater demand on the heating system.

To help prevent the building from overcooling, the discharge temperature can be reset from average building temperature. Resetting the DA temperature upward has the effect of reducing the cooling capacity of the central air handling unit. The W7100 contains a unique, patented, reset algorithm. The graph of this algorithm is shown in Fig. 10.

Space sensors are strategically located in the building to measure average space temperature. It is recommended that at least four sensors be installed and wired to provide a signal proportional to the average sensor temperature. The setpoint of these sensors should be at the maximum desired cooling temperature of the building. If it is desired to conform to the Emergency Building Temperature Restriction Act, adjust the setpoint of the reset sensor to 78° F [26° C] or higher, the W7100 control point to 60° F [16° C] and the reset adjustments to 20° F [11.1° C].

In operation, as the average temperature drops below the setpoint of the reset sensors, the setpoint of the mechanical cooling is reset upward by an adjustable amount. The setpoint of the economizer is not reset upward until the average building temperature drops 6° F [3.3° C] below the setpoint of the reset sensors. As long as free outside air is available, the W7100 will try to subcool the building somewhat to force the fan system to run at a lower horsepower.

When the average temperature in the building drops more than 6° F [3.3° C] below the setpoint of the reset sensors, the economizer setpoint is reset upward to minimize the load on the heating system in the building.

In reset applications where high humidity may be a concern, an outdoor temperature control (T675) can be connected to W7100 reset input (terminals 6 and 7) to lock out reset whenever outdoor temperature is above 55° F to 60° F [13° C to 16° C]. Another alternative is to use an indoor humidity sensor. With either alternative, reset sensors can be bypassed by connecting a jumper across the W7100 reset terminals. DA temperature will then be maintained at the W7100 setpoint without reset.

### Outdoor Reset

As an alternative to space temperature reset, outdoor reset may be employed. The advantages of outdoor reset are that it is simple to apply and field wiring is not needed. The disadvantage of outdoor reset is that outdoor temperature change has little effect on the cooling load on many VAV systems; for example, the interior mall of a large shopping center. In this application, the major cooling load consists of solar heat, people and lighting.

In applications where outdoor temperature has a major effect on the cooling load in an application, outdoor reset has many of the same energy saving advantages of space reset. Fig. 11 shows the schedule for outdoor reset. Since the outdoor reset does not start setting down the mechanical cooling setpoint until the outdoor temperature reaches 70° F [21° C], the reset should be set so that the maximum discharge temperature is 65° F [18° C]. An example would be a 60° F [16° C] W7100 setpoint, and 5° F [2.8° C] of reset, or a 55° F [13° C] W7100 setpoint and a 10° F [5.6° F] reset. If high humidity is a concern, the reset input can be bypassed any time the outdoor temperature is higher than 55° F or 60° F [13° C or 16° C] by jumpering reset terminals 6 and 7. The W7100 will then establish control at the W7100 setpoint.

Outdoor reset should be employed only in those applications where outdoor conditions represent a significant factor of 50 percent or more on the cooling load of the building.

## VARIABLE AIR VOLUME MODULATING SYSTEMS

### Modulating Heat/Cool Systems

The W7100 has a modulating output for use in either modulated heating or modulated cooling systems such as boiler or chiller applications. The output commonly modulates the supply water valve to the cooling or heating coil as shown in Fig. 12.

The W7100E has a modulated heat output, a staged heat output, four stages of cooling, and is normally used in indirect fired gas heat/cool systems. A typical system configuration is shown in Fig. 13.

When used for heating/cooling applications, use the contacts on a switching relay to short terminals 9 and 10 for heating, and to enable or disable the heating and cooling actuators. The modulating motors must be spring return.

## SPECIAL APPLICATIONS

### Additional Stages of Heat

Control of up to six additional stages of on-off heating or cooling can be provided by adding a W7101A Satellite Sequencer to the W7100 System. The W7101A can provide either 2-heat/4-cool or 4-heat/2-cool stages, selected by a jumper at terminals 6 and 7 on the W7101A.

The fixed resistor value across the W7100 terminals 7 and 8 (Table 2) must agree with the combined number of switched heating/cooling stages controlled by the W7100 and W7101A. Do not include any modulating stages controlled by the W7100.

**Night Setback and Morning Warmup**

There are several possible alternatives for controlling night setback and morning warmup in VAV systems. One alternative, shown in Fig. 15, makes use of a time clock to control the unoccupied mode of operation. The time clock starts the unoccupied mode by de-energizing the W7100, shutting down the system blower, and driving the economizer closed. During the unoccupied period, if the building temperature falls below the setpoint of the night thermostat(s), both the blower and the heating system will be energized. When the night thermostat is satisfied, the blower and heat will cycle off.

The time clock then initiates the morning warm-up, signaling the daytime or occupied mode of operation. During the morning warmup period, the W7100 remains de-energized, the system blower starts and the economizer remains closed. If the return air is below return air setpoint, heat is energized. The system remains in the morning warm-up mode until the return air rises above the setpoint of the return air control. At this point, the system returns to the day mode of operation. At the start of the day mode, the W7100 is energized, and the economizer is allowed to modulate. The system cannot reenter the morning warm-up mode of operation until the next night cycle.

The night setback and morning warm-up options must be used only on systems with VAV terminals designed for night setback. These terminals have built-in thermostats that cause the box to open if the delivered air temperature is above the thermostat setpoint, typically 80° F [27° C].

**Electric to Pneumatic Interface and Control**

The W7100D can control pneumatically actuated systems by using a Q642A as an interface. The Q642A Output Module amplifies the W7100D modulating output voltage from 0.2 to 1.7 Vdc, to a 2 to 10 Vdc level. An input and output for two separate channels are used to control electric/pneumatic transducers.

The W7100D can be used to provide heating only, cooling only, or heating/cooling operation using a T675A changeover control and a switching relay. A cooling only hookup with an economizer is shown in Fig. 16. All system components must be powered from the same control transformer to ensure a common electrical ground reference.

The Q642A should have the Y start settings adjusted to about 5° C [41° F]. This corresponds to a voltage of 0.94 Vdc, which is the midpoint of the economizer output voltage range. When the economizer output is 0.2 Vdc, the Q642A output should be 2 Vdc. The throttling range setting should be set to 5.5° C [41.5° F] to yield the full 2 to 10 Vdc output over the W7100 output voltage range.

The Y output of the Q642A Output Module is connected to the Y input of the RP7507A Electric/Pneumatic Transducer. The RP7507A converts the 2 to 10 Vdc voltage input signal to a 3 to 14 psi control pressure on the pneumatic line.

**Reset from Pneumatic Zone System**

In most pneumatic systems, the zone dampers are pneumatically controlled. Reset of the discharged temperature can be accomplished from the zone of highest demand by using an L91B1035 Pressure Transducer and an RP913 Hi/Lo Pressure Signal Discriminator.

As shown in Fig. 17, representative zone pneumatic thermostat signals are used as RP913 input signals. The RP913 selects the highest value signal and outputs a pressure signal corresponding to that of the highest zone demand. The L91B1035 converts the signal to a resistance value which is used as the reset input to the W7100. The 1715 ohm one percent resistor is used to establish the proper resistance range.

**W7100 RESET SPECIFICATIONS**

The W7100 controller can reset the discharge air/water temperature upward based on space or outdoor air temperature. This is accomplished by applying a specific resistance across terminals 6 and 7, 1715 ohms for no reset and 1760 ohms for full reset.

For space reset, use an S963B1037 Manual Potentiometer and a T7047C1025 Space Sensor in series. As the average space temperature drops below the setpoint of the reset sensor, the W7100 discharge temperature setpoint is reset upward by an adjustable amount, 5 to 20 degrees for cooling and 20 to 80 degrees for heating, until maximum reset occurs when the average space temperature is three degrees below the setpoint of the reset sensor or sensors. At this time, the W7100 setpoint is fully reset (see Fig. 18).

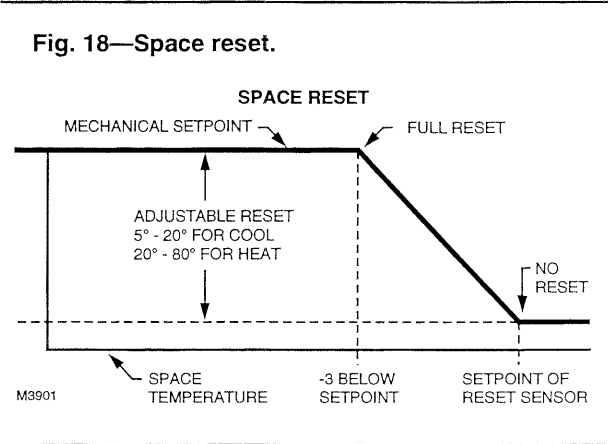
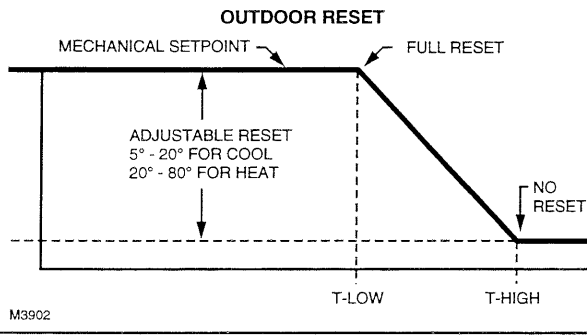

Fig. 18—Space reset.

For outdoor reset, use a C7031G1016 outdoor sensor (range -40° F to +110° F). Outdoor reset starts at 90° F (T-HIGH) and is fully reset at 70° (T-LOW). See Fig. 19. The No Reset and Full Reset temperatures can be changed by adding resistors in series/parallel with the C7031G1016 (see Fig. 20). Fig. 20 resistance values can be found in Table 3 for changing the cooling temperatures and in Table 4 for changing the heating temperatures.

**Fig. 19—Outdoor reset.**



Using the applicable table (cooling or heating), select the point at which no reset to the W7100 setpoint will occur

**Fig. 20—Series/parallel resistance wiring for W7100 reset.**

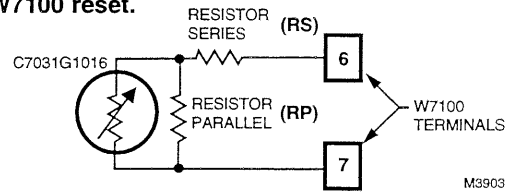

(T-HIGH) and the point at which you desire the W7100 to be fully reset (T-LOW). At the intersection of the two points is the value of the resistor to be placed in series ( $R_S$ ) and the value of the resistor to be placed in parallel ( $R_P$ ). Indicated resistor values are standard resistors and can be purchased locally.

**TABLE 3—SERIES/PARALLEL RESISTORS FOR COOLING.**

T-HIGH (NO RESET)		T-LOW (FULL RESET)					
		75	70	65	60	55	50
100	RP	14.7K	8.2K	5.6K	4.4K	3.6K	3.1K
	RS	200	310	415	490	560	620
95	RP		14.7K	8.2K	5.6K	4.4K	3.6K
	RS		190	300	410	485	560
90	RP			14.7K	8.2K	5.6K	4.4K
	RS			180	295	400	480
85	RP				15.0K	8.4K	5.6K
	RS				170	280	395
80	RP					15.0K	8.4K
	RS					160	275
75	RP						15.0K
	RS						150

**TABLE 4—SERIES/PARALLEL RESISTORS FOR HEATING.**

T-HIGH (NO RESET)		T-LOW (FULL RESET)					
		30	25	20	15	10	0
60	RP	8.6K	5.9K	4.6K	3.8K	3.3K	2.6K
	RS	240	350	430	500	560	660
55	RP	17.5K	8.6K	5.9K	4.6K	3.8K	2.9K
	RS	90	230	340	420	500	610
50	RP		17.5K	8.8K	6.0K	4.6K	3.3K
	RS		80	220	330	420	550
45	RP			17.5K	8.8K	6.0K	3.9K
	RS			70	210	320	480
40	RP				17.5K	8.8K	4.7K
	RS				60	200	400
35	RP						8.8K
	RS						190

# Settings and Adjustments

**SETPOINT KNOB:** Set for desired discharge air temperature (55° F to 60° F [13° C to 16° C] is typical).

**RESET KNOB:** Set for desired cool reset (outer scale) or heat reset (inner scale) as required (20° F [11° C] typical).

**CONTROL BAND KNOB:** Set for desired control band.

Increasing the control band setting slows down the machinery and increases the temperature deviation. Turning down the control band to a lower setting speeds up the machinery and reduces the temperature deviation. Refer to Table 5.

TABLE 5—RECOMMENDED STARTING CONTROL BAND SETTING.

	Number of Changes				
	2	4	6	8	10
VAV Cooling	8	6	4	3	2
VAV Heating	16	12	8	6	4

The controller range should be as narrow as possible without causing hunting or rapid cycling, regardless of load conditions. If instability or hunting occurs at the suggested setting, widen the control band.

## ECONOMIZER CHANGEOVER OPTION.

In installations using an economizer and enthalpy control, an outdoor air changeover controller limits the economizer to the minimum position when enthalpy is above setpoint. Set the H205 dial to the **A** position.

## SETTING NUMBER OF CONTROLLED STAGES

A fixed resistor is installed across the number of stages input (terminals 7 and 8). The resistor value tells the W7100 how many stages of heating and cooling are to be controlled. This affects the control behavior and determines how many stages the W7100 will turn on and off.

A 400 or 600 ohm resistor is initially installed on terminals 7 and 8. This corresponds to the value for controlling four or six stages of heating or four or six stages of cooling. If the system being installed has more or fewer stages of heating and cooling, this resistor must be changed to the value shown in Table 2. These resistors are contained in 4074EFV Bag Assembly, available separately (see W7100 System Accessory Chart). The new value will represent the actual number of switched heating/cooling stages operating under control of the W7100. This includes any stages on a W7101A Sequencer connected to the W7100 control. Refer to Table 2.

# System Checkout

Use Table 6 to perform a checkout of the W7100 Controller in the cooling mode.

TABLE 6—W7100 CONTROLLER CHECKOUT, COOLING MODE.

Step	Action	Verification
1	Open electrical disconnects on compressors	—
2	Connect 195770A Test Plug from 4074EDJ Bag Assembly to W7100 to disable most time delays. Jumper remote setpoint potentiometer terminals P-P1 and jumper reset terminals 6 and 7. Be sure that heating changeover terminals 9 and 10 are open. Set control band initially to 10° F.	—
3	Disconnect C7100 sensor from terminals T-T1. Connect 3400 ohm resistor (blue leads) from 4074EDJ Bag Assembly at terminals T-T1 to simulate 60° F [16° C] discharge temperature. Adjust setpoint knob to 56° F [13° C]. If an economizer is not used, connect terminal 9 to Y through a 510 ohm resistor.	—
4	Apply power. For W7100 with economizer and without 510 ohm resistor.	After about two minutes, the LEDs should indicate that cooling outputs are staging on. (The economizer requires this time to go fully open.)
5	Adjust the setpoint knob to 64° F [18° C]. After verification, immediately proceed to step 6.	Cooling LEDs should indicate staging off in about ten seconds.

(continued)

TABLE 6—W7100 CONTROLLER CHECKOUT, COOLING MODE (continued).

Step	Action	Verification
6	Return setpoint knob to 56° F [13° C]. If reset is used, proceed to next step. If not, go to step 10.	Cooling LEDs should indicate staging on in about ten seconds.
7	Adjust reset knob to 15° F [-9° C] cooling, the setpoint at 41° F [5° C], and replace the jumper at reset terminals (6 and 7) with the 1780 ohm resistor (red leads) from 4074EDJ Bag Assembly to simulate a call for maximum reset.	The cooling LEDs should remain on.
8	Adjust the setpoint knob to 49° F [9° C]. After verification, immediately proceed to the next step.	The cooling LEDs should indicate all stages off within one to two minutes.
9	Remove the 1780 ohm resistor (red leads) from reset terminals 6 and 7 and replace with a jumper. Adjust setpoint knob to 56° F [13° C].	The cooling LEDs should indicate all stages on within one minute.
<b>Economizer</b>		
10	Disconnect motor leads W, R, B, and Y. Jumper terminals R-W and R-B on the economizer motor. Remove jumper after verification.	Economizer motor should drive to mid position. This verifies proper motor operation.
11	With all cooling LEDs on and motor leads disconnected, measure the dc voltage at terminals R (negative) to W (positive).	Voltage should measure 1.9 Vdc ± 0.2 Vdc.
12	Adjust setpoint knob to 64° F [18° C] to drive economizer outputs to minimum position. Measure the dc voltage at terminals R (negative) to W (positive) after about five minutes.	The cooling LEDs should indicate all stages off within one to two minutes. The R-W voltage should drop to above 0.2 Vdc after five minutes.
13	Disconnect power to W7100.	—
14	Measure the resistance across terminals: R-W R-B R-Y	Resistance should be as follows: R-W: 226 ohms R-B: 432 ohms R-Y: 226 ohms
15	Reconnect economizer motor terminals W, R, B, and Y. Remove 3400 ohm resistor (blue leads) from terminals T-T1 and reconnect C7100 Sensor. Remove test plug and reinsert red dust cover on bottom of W7100. Adjust setpoint and reset (if used) to original settings.	—
16	Close electrical disconnects on compressors.	—



Use Table 7 to perform a checkout of the W7100 Controller in the heating mode.

TABLE 7—W7100 CONTROLLER CHECKOUT, HEATING MODE.

Step	Action	Verification
1	Open electrical disconnects on compressors.	—
2	Remove red dust cover and connect 195770A Test Plug from 4074EDJ Bag Assembly to W7100 to disable most time delays. Jumper remote setpoint potentiometer terminals P-P1 and jumper reset terminals 6 and 7. Be sure that heating changeover terminals 9 and 10 are closed (jumper if necessary).	—
3	Disconnect C7100 sensor from terminals T-T1. Connect 3400 ohm resistor (blue leads) from 4074EDJ Bag Assembly at terminals T-T1 to simulate 60° F [16° C] discharge temperature. Adjust setpoint knob to 64° F [18° C].	—
4	Apply power.	Within ten seconds the LEDs should indicate that heating outputs are staged on.
5	Adjust the setpoint knob to 56° F [13° C].	Heating LEDs should indicate staging off within 45 seconds.
6	Return setpoint knob to 64° F [18° C]. If reset is used, proceed to next step. If not, skip to step 9.	Heating LEDs should indicate all stages on in about 30 seconds.
7	Adjust reset knob to 20° F [11° C] heat, setpoint knob to 44° F [7° C]. Replace the jumper at reset terminals 6 and 7 with the 1780 ohm resistor (red leads) from 4074EDJ Bag Assembly to simulate a call for maximum reset.	The heating LEDs should remain on.
8	Remove jumper from heat changeover terminals 9 and 10 if installed in step 2. Remove 3400 ohm resistor (blue leads) from terminals T-T1 and reconnect C1700 sensor. Remove test plug and reinsert red dust cover on bottom of W7100. Adjust setpoint and reset (if used) to initial settings.	—
9	Close electrical disconnects on compressors.	—

Use the applicable sections of Table 8 as a guide in troubleshooting the W7100 Controller.

TABLE 8—W7100 TROUBLESHOOTING GUIDE.

Problems	Possible Cause	Corrective Action
All heat stages lock on.	1. Remote setpoint terminals open cause setpoint to be interpreted as 143° F [62° C]. 2. Shorted sensor terminals T-T1 interpreted as -2° F [-19° C]. 3. System malfunction.	1. Correct wiring or jumper P-P1. 2. Correct wiring. 3. Consult HVAC manufacturer equipment manual and/or building engineering requirements.
Discharge temperature too high.	1. Integral setpoint not at minimum position when used with remote setpoint. 2. System malfunction.	1. Set integral setpoint at minimum position if remote setpoint used. 2. Consult HVAC manufacturer equipment manual and/or building engineering requirements.
No heat.	1. Open sensor terminals T-T1 interpreted as 239° F [115° C] discharge (cooling locked out). 2. System malfunction.	1. Correct wiring. 2. Consult HVAC manufacturer equipment manual and/or building engineering requirements.
No cooling.	1. Shorted or open discharge sensor terminals T-T1. 2. Open reset terminals 6-7 interpreted as maximum reset. 3. Heat changeover terminal 9-10 shorted. 4. Remote setpoint terminals P-P1 open. 5. System malfunction.	1. Correct wiring. 2. Jumper terminals 6-7 or connect reset thermometer and verify resistance as per Fig. 10. 3. Remove jumper at 9-10 or correct timer. 4. Jumper terminals P-P1 or connect remote setpoint thermometer. 5. Consult HVAC manufacturer equipment manual and/or building engineering requirements.
Short cycling.	1. Test plug left inserted in bottom of W7100. 2. System malfunction.	1. Remove test plug. 2. Consult HVAC manufacturer equipment manual and/or building engineering requirements.



**Honeywell**

---

**Home and Building Control**

Honeywell Inc.  
1985 Douglas Drive North  
Golden Valley, MN 55422

Printed in U.S.A.

**Home and Building Control**

Honeywell Limited—Honeywell Limitée  
740 Ellesmere Road  
Scarborough, Ontario  
M1P 2V9

*Helping You Control Your World*



QUALITY IS  
KEY