

Selectra® SERIES 14 INSTALLATION INSTRUCTIONS and field service check list



A1014 Amplifier



A1014L1 Amplifier /
AD1014/AD1014L1
Amplifier-Selectors



AD1214 Amplifier



Mixing Tube and Sensor



Override Stat



Remote Temperature Selector



Valves



Table of Contents	
Page 2	Introduction and Dimensions
Page 3	Specifications
	Installation of Components
Page 4 & 5	Field Service Checklist
Page 6	Preliminary Circuit Analysis
	Low Fire Start Time Adjustment
	Sensitivity Adjustment
Page 7	Wiring Diagrams
Page 8	Temperature Calibration
	Valve Adjustments

System Components

Amplifiers:

A1014 (use with all temperature ranges)

A1014L1 (all ranges - adjustable low fire start duration)

Amplifier-Selectors: (with integral temperature dial)

AD1014-5590 (55° to 90° F)

AD1014L1-5590 (55° to 90° F - adjustable low fire start duration)

Dual Temperature Amplifier-Selectors:

AD1214__ (integral dual selector - any comb. of 2 standard ranges avail.)

Example - AD1214BC (120° to 170° F and 160° to 210° F, use w/TS214BC

Example - AD1214AD (80° to 130° F and 200° to 250° F, use w/TS214AD

Remote Temperature Selectors:

TD114 (55° to 90° F w/override 0° to 40° over set point)

TD114A (80° to 130° F)

TD114B (120 to 170° F)

TD114C (160° to 210° F)

TD114D (200° to 250° F)

TD114E (100° to 250° F)

TD114F (40° to 80° F w/override 0° to 40° over set point)

TD114G (90° to 140° F)

TD114-1 (55° to 90° F w/120° to 170° F override) * use w/TS114

TD114-2 (55° to 90° F w/two outputs)

TD114G-2 (90° to 140° F w/two outputs)

NOTE: Remote Selector and Discharge Temperature Sensor must have same temperature range to be compatible.

Optional: ETD-1 enclosure, EFP-1 cover plate only - no enclosure

Discharge Air Temperature Sensors: use with Mixing Tube

TS114 (55° to 90° F)

TS114A (80° to 130° F)

TS114B (120° to 170° F)

TS114C (160° to 210° F)

TS114D (200° to 250° F)

TS114E (100° to 250° F)

TS114F (40° to 80° F)

TS114G (90° to 140° F)

TS214__ (dual sensor - any combination of 2 standard ranges available)

Example - TS214G (55° to 90° F and 90° to 140° F, use w/TD114 & TD114G, or TD214G [selector w/switch], or AD1214G)

Example - TS214AD (80° to 130° F and 200° to 250° F, use w/TD114A & TD114D, or TD214AD [selector w/ switch], or AD1214AD)

Mixing Tubes: use with Sensors

MT1-9 or 2-9 (9" length)

MT1-12 or 2-12 (12" length)

MT1-23 or 2-23 (23" length)

MT1-28 or 2-28 (28" length)

MT1-57 (57" length)

Valves:

M411 (3/8" & 1/2" pipe size)

M511 (1/2" & 3/4" pipe size)

M611 (3/4" & 1" pipe size)

MR212D (1", 1-1/4", 1-1/2" pipe size)

MR212E (1-1/2" & 2" pipe size)

MR212G (2-1/2" & 3" pipe size)

MR212J (4" flanged)

MR212-2D, E, G, J (same as above except used for 2-speed blower or dual fuel operation)

NOTE: M (Modulator) valve requires a pressure regulator for high fire setting. MR (Modulator-Regulator) valve requires no pressure regulator up to 5 psi.

Optional:

Dual Temperature Selector:

DOORHEATERS-

TD114HD use w/TS114 (door closed 55° to 90° F/open 90° to 140° F)

PAINT SPRAY BOOTHS OR OTHER DUAL APPLICATIONS-

TD214__ (dual selector w/switch - any comb. of 2 standard ranges avail.)

Example - TD214G (55° to 90° F [spray] and 90° to 140° F [dry], use w/TS214G

Example - TD214AD (80° to 130° F and 200° to 250° F, use w/TS214AD

TD214__X (same as TD214 __, less enclosure)

Inlet Air Temperature Sensors: use with Mixing Tube

TS10765A (8:1 ratio)

TS10765B (5:1 ratio)

TS10765C (3.5:1 ratio)

Override Stat: (use only with TD114, F, -1)

T115 (40° to 90° F)

Introduction and Dimensions

Selectra SERIES 14 electronic gas flame modulation systems are designed primarily for make-up air heating, as components of direct fired equipment. They may be field installed on existing equipment or specified for new equipment installation. Natural, manufactured, mixed, LP and LP gas air mixture are compatible gases.

The systems utilize Modulator or Modulator-Regulator valves. Amplifiers are available with adjustable low-fire start duration, and with integral or remote temperature selection. A discharge air temperature sensor is mounted within a mixing tube housing.

Optional - a room override thermostat provides space temperature control by raising the discharge air temperature to a pre-selected point - when used in conjunction with the remote temperature selector.

Optional - an inlet air sensor (and mixing tube) provides inverse change in discharge air for each degree change in inlet air - when installed in a convenient duct location upstream of the burner.

Optional - a dual temperature selector replaces TD114 to provide dual control for door heaters, or other applications such as paint spray booths (TD214_ or _X, or AD1214_).

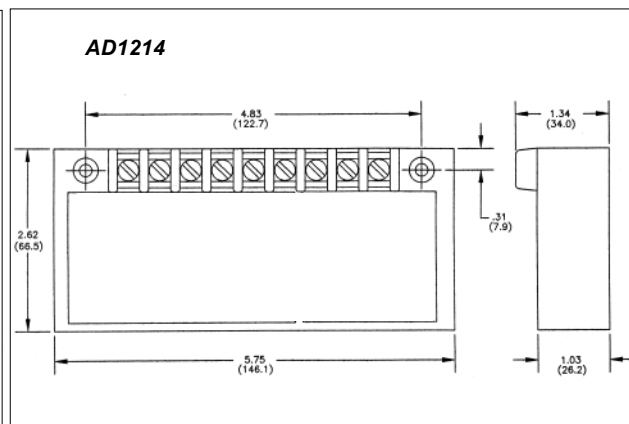
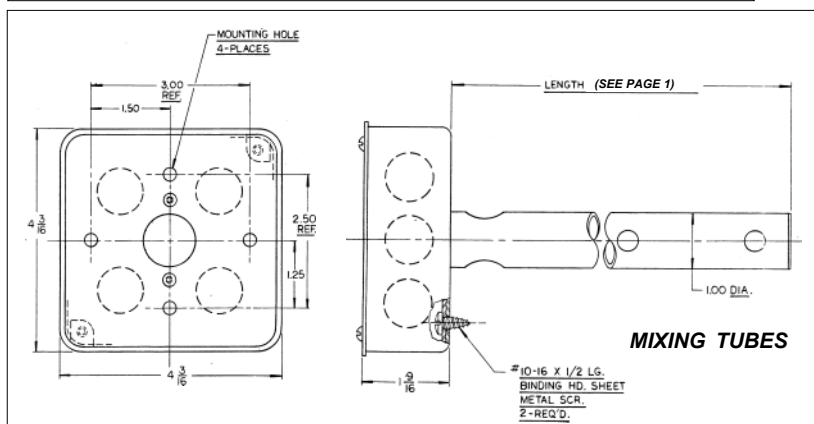
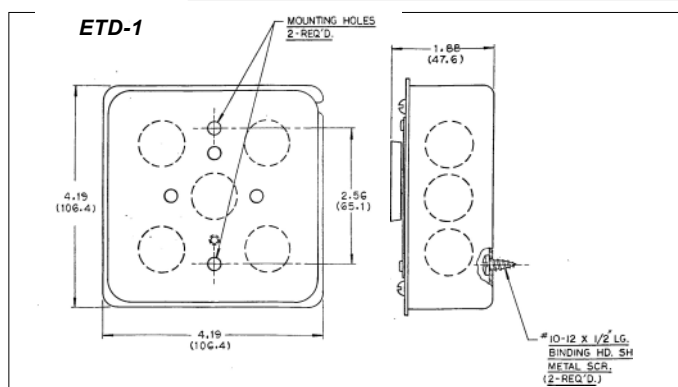
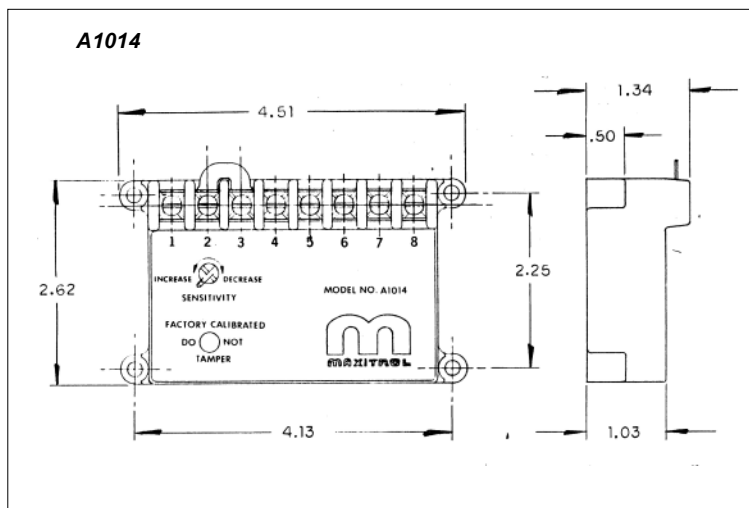
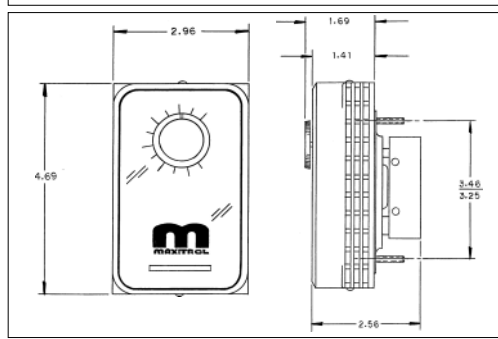
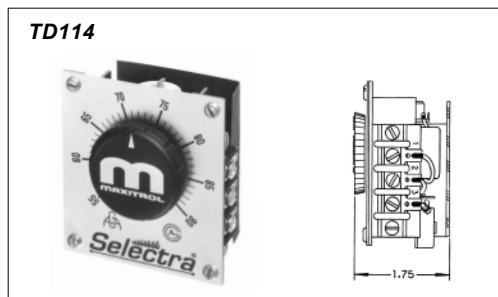
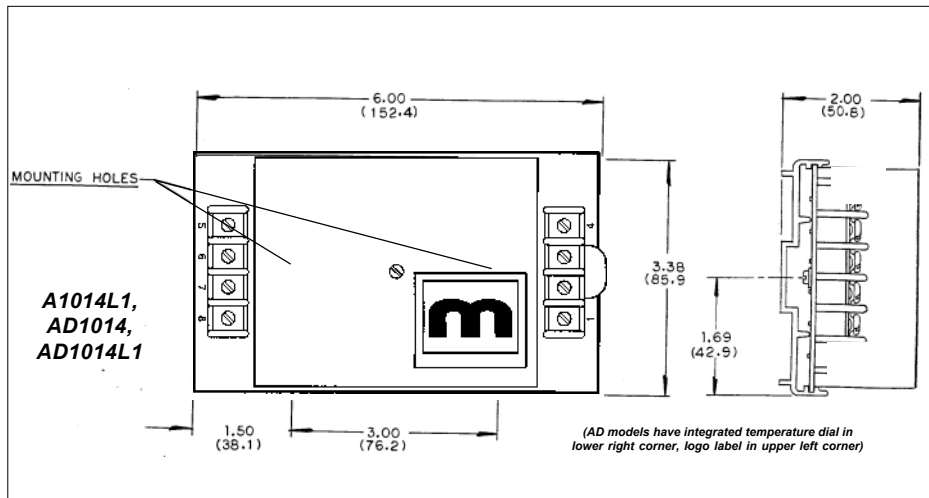

Specifications

Power Requirements: 24 VAC, 50/60 Hz Class II transformer

NOTE: Transformer secondary must not be grounded in any portion of the circuit external to a Maxitrol amplifier. If existing transformer is grounded, a separate isolated transformer must be used. Electrical interference may effect performance and/or damage equipment.

Ambient Limits:

Operating.....-40° to 125° F / -40° to 52° C

Non-operating.....-50° to 185° F / -46° to 85° C

Gases: Natural, Manufactured, Mixed, LP, LP Gas Air Mixture

Vent: M411, 511, 611.....vertical vent outlet 1/8" NPT - 12A06 installed

MR212.....two vents located in upper housing, both equipped with vent limiting means

Pressure Limits:

Maximum Discharge Pressure (M411, 511, 611).....7" w.c. / 17 mbar

Static Pressure Rating (M411, 511, 611).....5.0 psi / 345 mbar

Maximum Operating Inlet Pressure

M411, 511, 611.....1 psi / 70 mbar

MR212.....5.0 psi / 345 mbar

Maximum Emergency Exposure*

M411, 511, 611.....3.0 psi / 210 mbar

MR212.....12.5 psi / 862 mbar

* May not function properly at this pressure, but will suffer no internal damage

Installation of Components

Control wires connected to the Override Stat, Discharge Air Sensor, or Remote Temperature Selector must not be run close to or inside conduit with power or ignition wires. Doing so may cause the unit to function erratically or may destroy the amplifier. If shielded wires are used, shield must be insulated and grounded at the amplifier location only.



Wiring Run: If control wiring is inside conduit with line voltage wiring, use shielded cable up to 100 ft. For best results up to 200 ft., run control wiring in separate conduit. For longer runs see Remote Selector below.

Amplifier / Amplifier-Selector: contains the wiring terminals and sensitivity adjustment - install in any convenient location that is protected from the weather and contaminated atmosphere.

Remote (or Dual) Selector: Install in control cabinet or other chosen location. NOTE: Suffix letters must match, e.g. TS114A must be used with TD114A. For wiring runs longer than 200 ft. substitute ES261-1/ES261-2 for TD114. The ES261s are a 2-piece version of the TD114. ES261-1 is a temperature setting dial only, ES261-2 must be mounted at furnace location.

Discharge Temperature Sensor / Mixing Tube

Assembly: sensor housed in mixing tube, install in discharge air stream.

Optional:

Dual Temperature Selector: see preceding Remote/Dual selector.

Room Override Stat: mount in heated area not in direct path of discharge air stream.

Inlet Air Sensor: install in convenient location upstream of burner, in intake air duct.

Typical Gas Trains

Modulator (M) or Modulator-Regulator (MR) Valve: Mount in upright position in horizontal run of pipe, downstream of other controls - a separate gas pressure regulator must be used with any modulator (M) valve.

MR Valve: Modulator-regulator valve

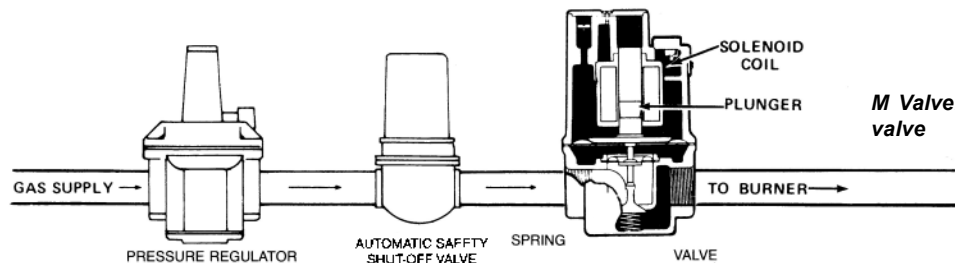
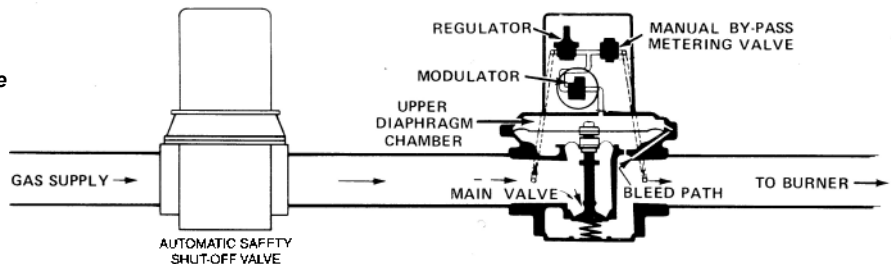

M Valve: Regulator upstream of modulator valve

Field Service Checklist

SYMPTOM	POSSIBLE CAUSE	FIELD TEST	REMEDY
A. No gas flow.	1. Modulating valve improperly installed (or see Symptom 'L').	1. Arrow on side of Valve should point in direction of gas flow.	1. Install properly.
B. Continuous Low Fire (electronics problem).	2. Short circuit or no voltage to the amplifier. 3. Open circuit in TD 114, Remote Temperature Selector circuit or wiring. 4. Short circuit in TS114, Discharge Air Sensor circuit or wiring. 5. Faulty amplifier.	2. Check for 24V AC at amplifier terminals 7 and 8. 3. Inspect for loose or broken wires between amplifier terminals 1 and 2, and TD114 terminals 1 and 2, and TD114 terminals 1 and 3. 4. Connect test resistor as described in Preliminary Circuit Analysis. Follow procedure outlined. 5. Check items 2, 3 and 4.	2. Prove the power source. 3. Tighten connections or replace wiring. 4. If modulating voltages are obtained, Check TS114 circuit for shorts. Replace TS114 if necessary. 5. If items 2, 3, and 4 check out and modulating voltages are still not obtained, amplifier may be assumed faulty. Replace.
C. Continuous Low Fire (electronics OK)	6. Short circuit or open circuit in Modulator Coil. 7. Plunger missing, jammed or improperly installed.	6. Measure resistance across modulator terminals with connecting wires detached. 7. Inspect. Plunger should be installed per diagrams page 3 and operate freely in solenoid sleeve.	6. Replace modulator head if not approximately 45-55 ohms for M611 Valve and 60-80 ohms for MR212 Valve. 7. Clean or replace plunger if necessary. Install as per diagrams page 3.
D. Incorrect Minimum Fire Erratic or Pulsating Flame.	8. Incorrect by-pass metering valve adjustment. 9. Excessive negative burner pressure.	8. See valve adjustments on page 8. 9. Close main gas supply and measure manifold pressure with blower operating. Reading should be less than 1.5" w.c. negative pressure.	8. Adjust to proper minimum fire. 9. If reading is greater than 1.5" negative pressure, check for clogged filters or other inlet air restrictions. Consult factory for other solutions.
E. Continuous High Fire (electronics problem).	10. Short circuit in TD114 Remote Temperature Selector circuit or wiring. 11. Open circuit in TS114/TS10765. Discharge or Inlet Air Sensor Circuit or wiring. 12. Jumper not connected across amplifier terminals 2 and 3.	10. Inspect for shorts at or between Amplifier terminals 1 and 2 or TD114 terminals 1 and 3. 11. Check TS114/TS10765 for open internal circuit. Connect test resistor as described in Preliminary Circuit Analysis. Follow procedure outlined. 12. Inspect.	10. Correct wiring if shorts exist. 11. If modulating voltages are obtained, check TS114/TS10765 for open circuits. Replace TS114/TS10765. 12. Correct the wiring.
F. Continuous High Fire (electronics OK)	13. Foreign object holding valve open. 14. Plunger jammed.	13. Remove bottom plate and inspect valve and seat. 14. Inspect. Plunger should be smooth, clean, and operate freely in solenoid sleeve.	13. Clean seat. Clean valve or replace if necessary. 14. Clean, or if necessary, replace plunger.
G. Incorrect Maximum Fire.	15. Inlet pressure too low. 16. Incorrect outlet pressure adjustment of Pressure Regulator.	15. Read pressure at inlet to modulating valve using a manometer with unit operating at full fire. Pressure should be equal to the sum of outlet pressure setting plus pressure drop of the valve (see Maxitrol Capacity Chart). 16. Read manifold pressure using manometer and compare with recommendation of equipment manufacturer.	15. Increase inlet pressure if possible. 16. See valve adjustments on page 8.
H. Erratic or Pulsating Flame.	17. Hunting. 18. Erratic air patterns or improper TS114 location. 19. Wiring is run next to high voltage switching circuits causing induced voltages. 20. Faulty Amplifier or erratic voltage supply.	17. Adjust sensitivity control counter-clockwise. 18. Connect test resistor as described in Preliminary Circuit Analysis. Turn TD114 selector dial so heater goes through its entire modulating range. 19. Temporarily wire each of TD114, TS114, and MR212 externally and observe heater/equipment operation. 20. With test resistor connected (per item #18) and TD114 locally connected (per item #19), turn TD114 selector dial through entire modulating range. Observe D.C. voltage across modulator terminals.	17. If flame stabilizes, adjust sensitivity control to maintain an even flame. 18. If the flame is steady throughout the entire modulating range, the TS114 must be moved. 19. If smooth operation results, isolate effected wiring from source of induced voltage. If erratic or unstable D.C. voltages are obtained throughout the modulating range, the amplifier may be assumed faulty. Replace. If erratic operation is noted only over a small range of 2 or 3 volts, the voltage source may contain surges. Consult Maxitrol.
I. Incorrect Discharge Air Temperature.	21. Inlet Air Sensor is used. 22. Incorrect Wiring. 23. System out of calibration. 24. Improper TS114 location. 25. Room Override Thermostat circuit closed.	21. Inlet Air Sensor changes 1° for each 3.5°, 5°, or 8° outside temperature change from 60° (pre-determined – turndown varies with model used). 22. Check wiring diagrams page 7. 23. Sensing temperature (thermometer next to TS114) does not correspond to TD114 setting. 24. Sensing temperature (thermometer next to TS114) does not represent average discharge air temperature. 25. Remove Override Thermostat lead from terminal 2 of TD114.	21. Sensing temperature will vary from TD114 dial settings. This is intentional. 22. Correct wiring. 23. See calibration procedure. 24. Move TS114 to location where average representative temperature can be sensed. 25. TD114 dial setting, then check thermostat setting and/or check wiring for shorts.
J. Burned out Transformer.	26. Short circuit in modulator coil. 27. Short circuit between amplifier and modulator valve.	26. Measure resistance across modulator terminals with red lead wires disconnected. 27. Inspect wiring.	26. Replace modulator head if less than 40 ohms. 27. Correct wiring is short is found.
K. Discharge Air Temperature too Low when T115 is operative.	28. Too low an Override Temperature setting. 29. Burner capacity may be insufficient.	28. Check "Override Temperature Selector" of TD114. 29. Check for high fire (Maximum manifold pressure specified for heater).	28. Reset to correct temperature. 29. If on high fire, control can do no more. Heater unable to furnish additional heat to raise temperature.

Preliminary Circuit Analysis

For ease in troubleshooting, it is advisable to wire the system as follows (this differs from the normal connection). The Discharge Air Sensor is disconnected and replaced with a 10,000 ohm, 1/2 watt test resistor (terminals 3 and 4). If inlet air sensor is being used, disconnect and replace with a jumper. On units where the Remote Temperature Selector is located a considerable distance from the heater, it may be advantageous to connect the selector at the heater location.

Connect a DC volt meter (capable of reading 0-24 V DC) on the Modulator or Modulator-Regulator Valve terminals. Set the temperature to the minimum dial setting. The DC voltage should read 0 volts. The DC voltage should gradually increase to at least 20 volts as you slowly rotate the dial to the maximum dial setting. If these voltages are obtained, the valve function can now be checked out.

The operation of the Valve with regard to voltage is as follows: from 0 volts to approximately 5 volts, the modulating valve should be on bypass flow with the heater operating on low or minimum fire. From approximately 5 volts to 15 volts DC, the valve should be performing its modulating function, and the heater should be firing at a

modulated flow rate between low and high fire, depending upon the voltage. Above approximately 15 volts DC, the Valve should be delivering full flow to the heater and the unit should be on full fire. If the DC voltage is obtained on the Valve terminals, but the heater does not respond as described, the problem can be isolated to the valve itself or to the gas control manifold of the heater (see check list, pages 4 and 5).

In the event proper voltages are obtained, and the Valve responds correctly to these DC voltages, the problem could well be in the wiring leading to the Discharge Air Sensor or the Discharge Air Sensor itself. This should be also reviewed in the check list.

If the proper voltages are not obtained when wired as instructed, the problem can be isolated to the electronics and this may once again be reviewed in the check list.

After test, remove the test resistor and reconnect the Discharge Air Sensor to terminals 3 and 4. If Remote Temperature Selector has been moved return it to its original position.

Low Fire Start Time Adjustment

On A1014L1 and AD1014L1 amplifiers, the low fire start duration is adjustable from approximately 0-30 seconds, and begins timing after the amplifier has been energized.

High fire is delayed, and the M/MR valve remains in the low fire setting position during the delay time period.

Use a small screwdriver to adjust the time delay potentiometer.

Turn clockwise (+) to increase low fire start duration, and counter-clockwise (-) to decrease low fire start duration.

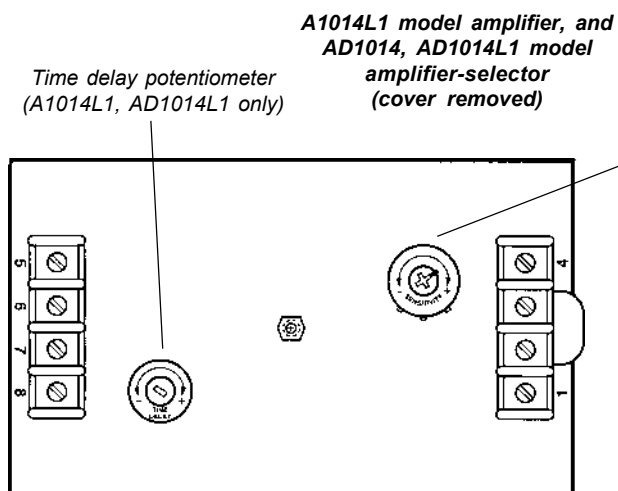

Sensitivity Adjustment

The sensitivity control will allow the user to control the response of the system. Caution should be exercised in the use of this adjustment. Under normal usage the pointer should be located on the mark on the label.

If hunting is encountered (rapid oscillation), rotating the sensitivity control counter-clockwise will dampen the oscillation - stabilizing the flame.

DO NOT adjust unless necessary, because decreasing the sensitivity will increase the temperature "DROOP" of the system.

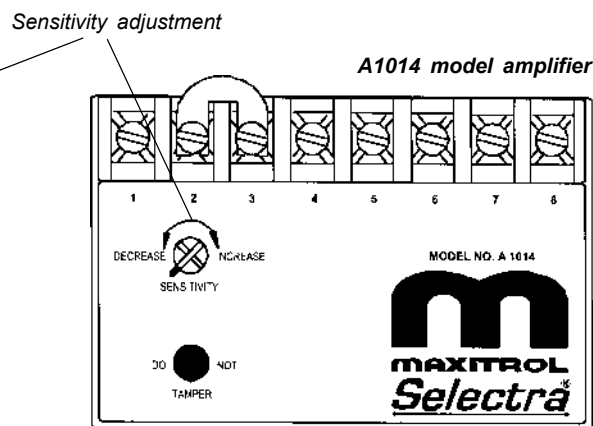

Wiring Diagrams

A1014 model amplifiers

WITH OPTIONAL ROOM
OVERRIDE STAT

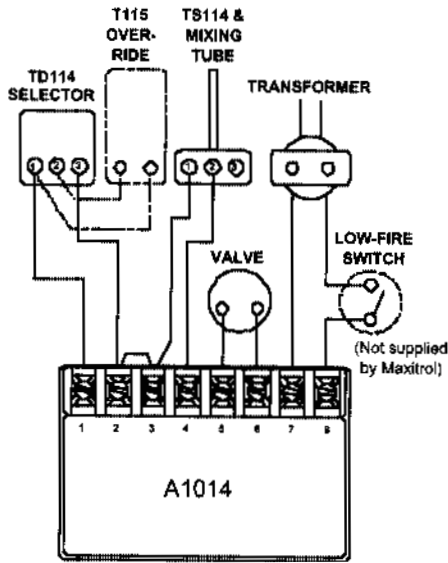
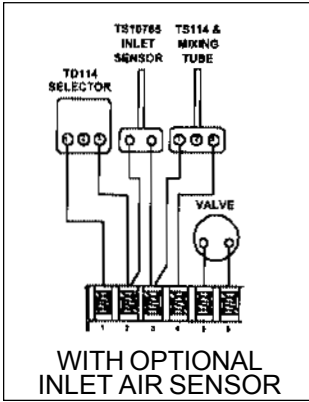

AD1214 model amplifiers

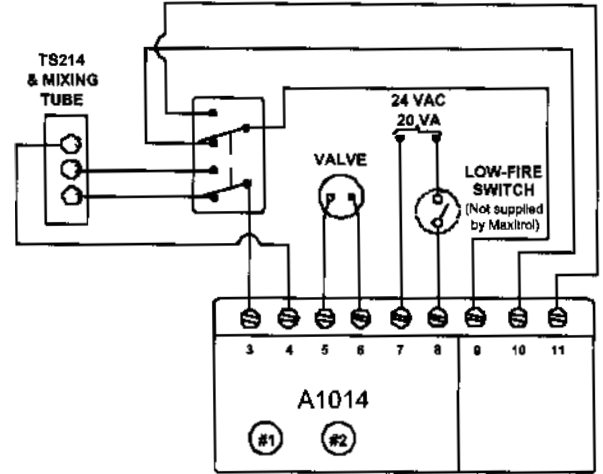

A1014L1 model amplifiers

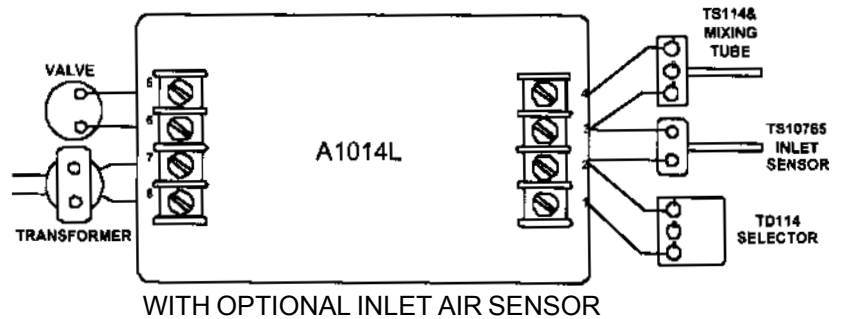
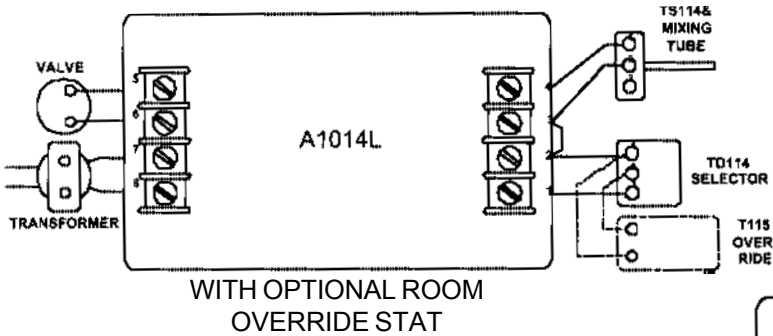

AD1014 / AD1014L1 model amplifier-selectors

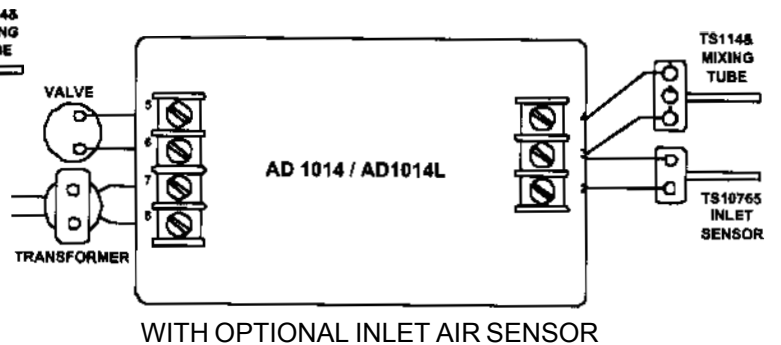
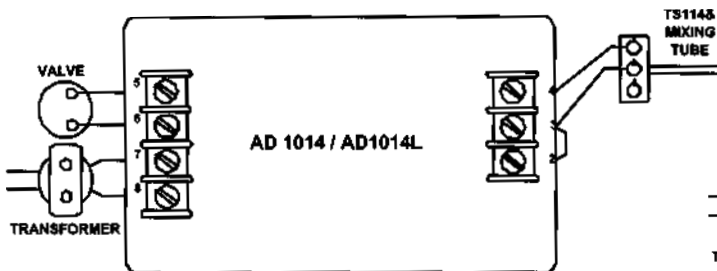

Temperature Calibration

NOTE: The components of this system are individually calibrated and are not part of a matched set. It is necessary to place an accurate temperature measuring device as near the Discharge Air Sensor as possible.

Set the Remote Temperature Selector at least 10 degrees above outside air temperatures.

If calibrating at the A1014 Amplifier: Adjust calibration potentiometer (A), until temperature reads the same as the set temperature. If the temperature is below the set point, then rotate calibration potentiometer clockwise. If the temperature is above the set point, rotate the potentiometer counter-clockwise.

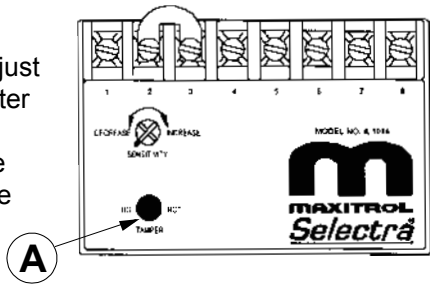

If calibrating at the TD114 Remote Temperature Selector: If measured temperature is below set temperature, rotate the calibration potentiometer clockwise until the correct temperature is obtained. If the temperature is above the set point the potentiometer should be turned counter-clockwise. Proceed slowly with the above steps so as to allow the temperature measuring instrument to catch up with the change in temperature.

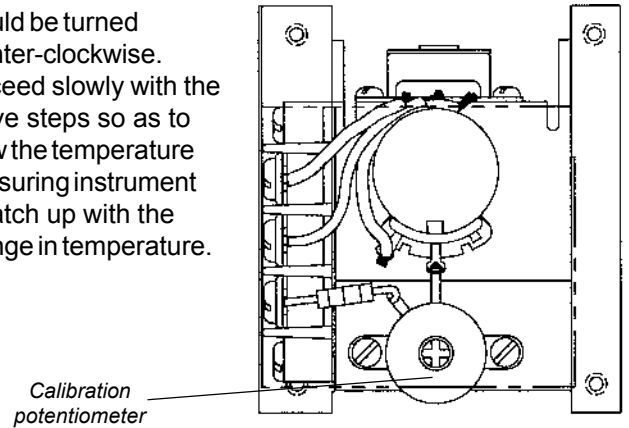

Valve Adjustments

(See bulletin MT2035 for additional M/MR valve information)

NOTE: Low fire adjustment should be checked whenever the high fire adjustment is changed.

MR 212 VALVE

High Fire Manifold Adjustments:

1. Disconnect wires from amplifier terminal #4. This causes the valve to call for continuous high fire.
2. Remove seal cap (A), and turn regulator pressure adjusting screw to obtain desired manifold pressure. (Clockwise rotation increases pressure.)
3. Reconnect the wires to amplifier terminal #4.

NOTE: If low fire bypass is on maximum, the desired high fire outlet pressure may not be achieved.

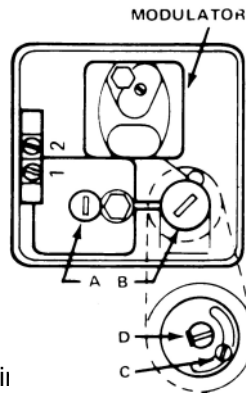

Low Fire or Bypass Adjustments:

1. Disconnect wire from amplifier terminal #8, this causes valve to call for continuous low fire.
2. Remove cap (B), and loosen lock screw (C). Turn (D) to desired low fire adjustment. (Clockwise rotation reduces minimum flow rate.)
3. Tighten set screw (C), replace cap (B) and reconnect wire to amplifier terminal #8.

M411, 511, 611 VALVE

High Fire Manifold Adjustments:

1. Disconnect wires from amplifier terminal #4, this causes the valve to call for continuous high fire.
2. Adjust the pressure regulator to obtain the desired manifold pressure (7" w.c. maximum).
3. Reconnect the wires to amplifier terminal #4.

Low Fire or Bypass Adjustments:

1. Disconnect wire from amplifier terminal #8, this causes the valve to call for continuous low fire.
2. Remove cap (A), and turn adjusting screw (B) to desired low fire adjustment. (Clockwise rotation reduces minimum flow rate.)
3. Replace cap (A), and reconnect wire to amplifier terminal #8.

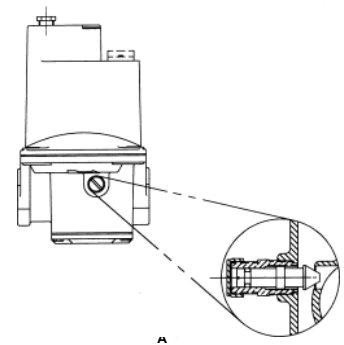

A copyrighted publication of

MAXITROL[®]  **company**

www.maxitrol.com

Maxitrol Company USA
23555 Telegraph Rd., P.O. Box 2230
Southfield, MI U.S.A. 48037-2230
248.356.1400 • Fax 248.356.0829

European Representatives
Warnstedterstrasse 3 06502 Thale, Germany
49.3947.400.0 • Fax 49.3947.400.200
Industriestrasse 1 48308 Senden, Germany
49.2597.9632.0 • Fax 49.2597.9632.99