

V4943A/V8943A On/Off Diaphragm Gas Valves

PRODUCT DATA

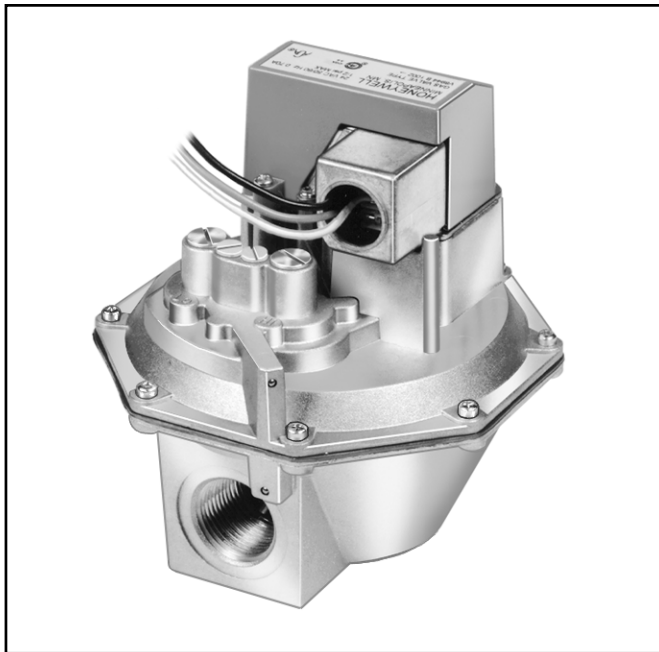

FEATURES

- V4943A used with line voltage, two-wire thermostat or controller.
- V8943A used with 24 Vac thermostat or controller.
- Valves open in less than six seconds.
- Rated for 0.5 psi (3.4 kPa).
- Rated for -40°F to +150°F (-40°C to 66°C).
- Firm closing; diaphragm is spring-loaded.
- Valves close on power failure; recommended for final shutoff service.
- 1/4 in. (6 mm) spade terminal electrical connections. Leadwires and cover for electrical conduit connections are provided.
- Designed as replacement valves for V4843A/V8843A.

APPLICATION

The V4943A and V8943A are solenoid-operated diaphragm valves suitable for Liquefied Petroleum (LP) and natural gases. They are normally used on atmospheric boilers, commercial water heaters, and rooftop heaters.

Contents

Application	1
Features	1
Specifications	2
Ordering Information	2
Installation	4
Wiring	6
Operation	6
Checkout and Troubleshooting	7



SPECIFICATIONS

Models (See Table 1):

- V4943A (120 Vac) solenoid-operated diaphragm valves for 0.5 psi (3.4 kPa) internal bleed.
- V8943A (24 Vac) solenoid-operated diaphragm valves for 0.5 psi (3.4 kPa) internal bleed.

Table 1. Models Available.

Model	Voltage and Frequency	Maximum Operating Pressure		Pipe Size (in.)	Thread Type
		(psi)	(kPa)		
V4943A	120V/60 Hz	0.5	3.4	1, 1-1/4, 1-1/2, 2	NPT
V8943A	24V/60 Hz	0.5	3.4	1, 1-1/4, 1-1/2, 2	NPT

Type of Gas:

Liquefied petroleum (LP) and natural gas.

Flow Capacity:

See Table 2.

Table 2. V4943A/V8943A Flow Capacity.

Model	Valve Size (in.)	AGA Rating for 0.64 sp gr Gas at 1 in. wc. Pressure Drop
V4943A	1	1,000,000
V8943A	1-1/4	2,100,000
	1-1/2	2,500,000
	2	3,000,000

Valve Pattern:

Straight-through, non-offset.

Valve Body Material:

Die-cast aluminum.

Electrical Ratings:

- V4943A Frequency: 60 Hz.
- V4943A Current: 0.055A maximum at rated voltage and frequency.
- V8943A Frequency: 50/60 Hz.
- V8943A Current: 0.363A maximum at rated voltage and frequency.

Electrical Terminations:

1/4 in. (6 mm) spade terminals (quick connects). Leadwires and cover for electrical conduit connections are provided.

Valve Opening Time:

Six seconds maximum.

Valve Closing Time:

On power failure, a maximum of 3 seconds at 7 in. wc inlet pressure.

Power Consumption:

- V4943A: 6 VA maximum.
- V8943A: 8 VA maximum.

Ambient Temperature Ratings:

-40°F (-40°C) to 150°F (66°C)

Dimensions:

See Fig. 1.

Weight:

- 1, 1-1/4 in. valves: 4 lb (1.8 kg).
- 1-1/2, 2 in. valves: 5 lb (2.3 kg).

Mounting Position:

Upright (horizontal).

Approvals:

- Underwriters Laboratories Listed: File Number MH1639, Guide Number YIOZ.
- International Approval Services (IAS): Report Number C2030020.
- (IAS is an AGA/CGA joint venture.)

Accessory:

- AT72D Transformer (40 VA) for all 24 Vac models.
- 204480 Vent Pipe Connector.

ORDERING INFORMATION

When purchasing replacement and modernization products from your TRADELINE® wholesaler or distributor, refer to the TRADELINE® Catalog or price sheets for complete ordering number.

If you have additional questions, need further information, or would like to comment on our products or services, please write or phone:

1. Your local Home and Building Control Sales Office (check white pages of your phone directory).
2. Home and Building Control Customer Relations
Honeywell, 1885 Douglas Drive North
Minneapolis, Minnesota 55422-4386

In Canada—Honeywell Limited/Honeywell Limitée, 35 Dynamic Drive, Scarborough, Ontario M1V 4Z9.

International Sales and Service Offices in all principal cities of the world. Manufacturing in Australia, Canada, Finland, France, Germany, Japan, Mexico, Netherlands, Spain, Taiwan, United Kingdom, U.S.A.

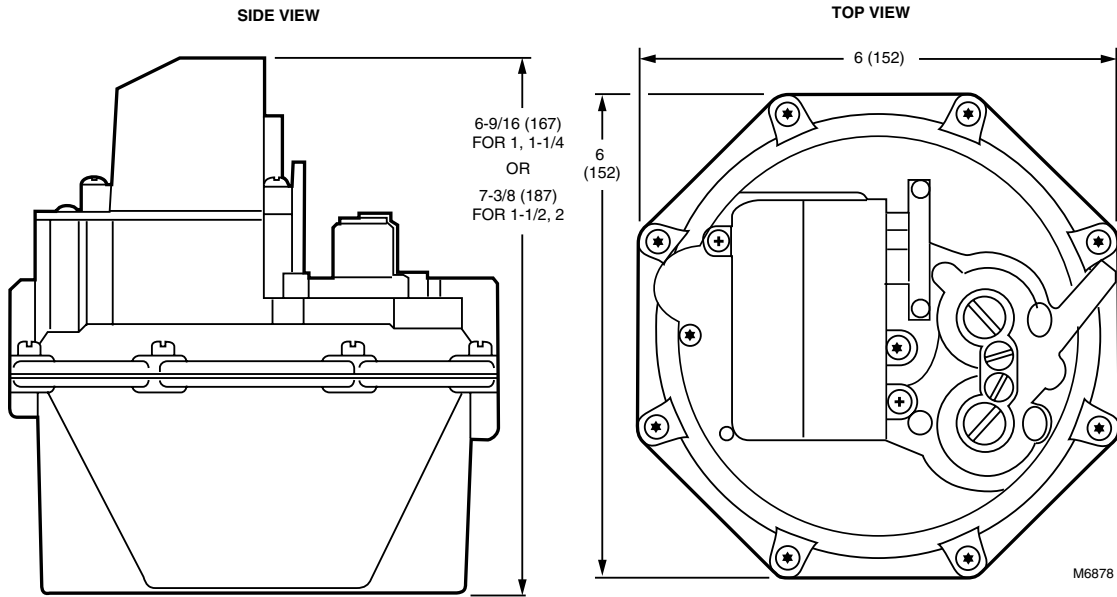

Fig. 1. V4943/V8943 dimensions in in. (mm).

Gas Valve Sizing

1. Check the burner nameplate for (a) the type of gas used, and (b) the gas flow capacity. The capacity is listed in British thermal units per hour (Btuh) or in cubic feet per hour (cfh).
2. Contact the local gas utility for information regarding (a) the specific gravity (sp gr) and (b) the Btu per cubic foot (Btu/cf) for the type of gas used.
3. Find the capacity in cfh. If the capacity is listed in Btu, convert to cfh by the following formula:

$$\text{Capacity in cfh} = \frac{\text{Btuh (burner nameplate)}}{\text{Btu/cf (gas utility)}}$$

4. For gases with specific gravities other than 0.64, multiply the burner cfh by the proper conversion factor in Table 2.

Table 3. Gas Conversion Factors.

Type of Gas	sp gr (average)	Multiply cf/h by
Manufactured	0.60	1.033
Mixed	0.70	0.956
LP-Propane	1.53	0.647
LP-Butane	1.98	0.569

5. Use the corrected capacity in cfh when determining the gas valve size in Fig. 2 through 5.
6. Determine the maximum pressure drop across the valve and draw a vertical line at this pressure on Fig. 2, 3, 4, or 5.
7. At the point of intersection of the vertical line and the curve, draw a horizontal line to intersect the flow (capacity) scale. The point of intersection indicates the capacity that can be obtained with the maximum pressure drop.

8. If the capacity at the maximum pressure drop is insufficient, use the capacity vs. pressure drop curve for the next larger valve size and repeat steps 6 and 7.

Sizing Two Identical Valves Piped in Series

1. Find the cfh for the type of gas used.
2. Consider both valves as one unit. Determine the maximum pressure drop across the one unit.
3. Find the pressure drop across the first valve by assuming it to be 45 percent of the total pressure drop.
4. Find the valve size in Fig. 2 through 5.

The second valve will be the same size as the first valve.

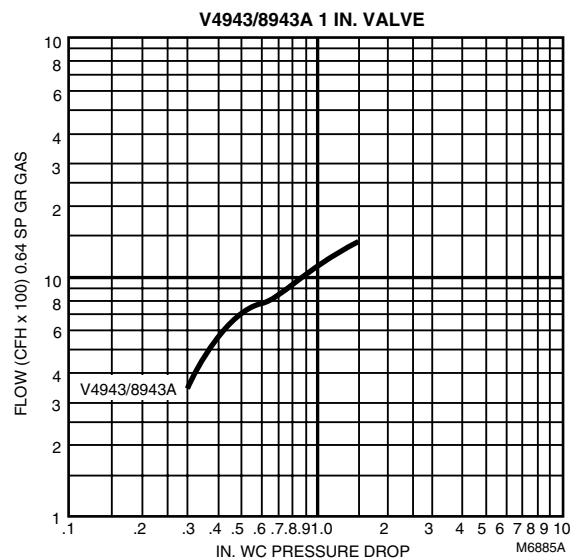

Figure 2. Capacity vs pressure drop curves for 1 in. valve.

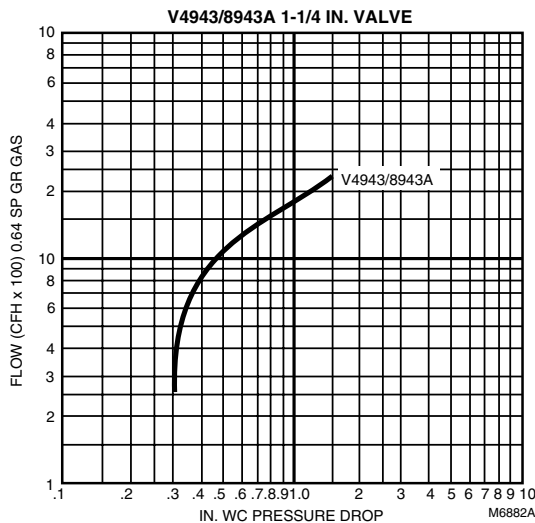

Figure 3. Capacity vs pressure drop curves for 1-1/4 in. valve.

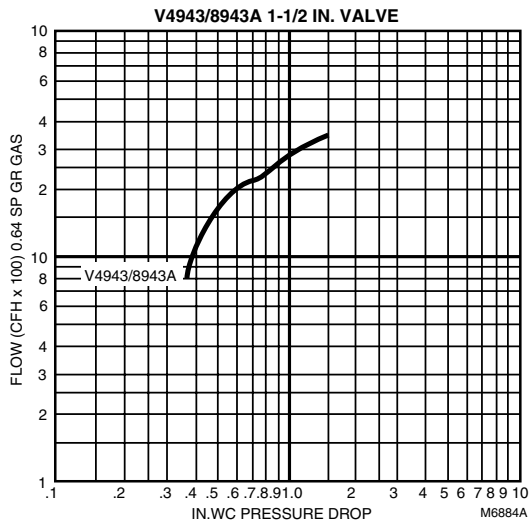

Figure 4. Capacity vs pressure drop curves for 1-1/2 in. valve.

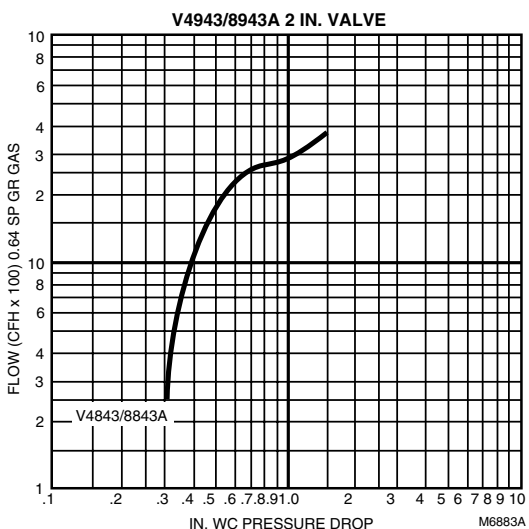

Figure 5. Capacity vs pressure drop curves for 2 in. valve.

INSTALLATION

⚠ WARNING

Potential Explosion Hazard.

Installation and service by trained professionals only. Exceeding the pressure rating or use of unspecified fuel can lead to improper operation of the valve and can create an explosion hazard. Property damage, severe bodily injury or death can result.

When Installing this Product...

1. Read these instructions carefully. Failure to follow them could damage the product or cause a hazardous condition.
2. Check the ratings given in the instructions and on the product to make sure the product is suitable for your application.
3. Installer must be a trained experienced flame safeguard control technician.
4. After installation is complete, check out product operation as provided in these instructions.

⚠ CAUTION

Prevent Possible Explosion/Fire Hazard

Prevent Electrical Shock/Equipment Damage

1. Turn off gas supply before starting installation.
2. Disconnect power supply before beginning installation to prevent electrical shock and equipment damage.
3. Do not remove seal over valve inlet or outlet until ready to connect piping.
4. Install valve in a horizontal pipe line in any upright position with the gas flow in the direction indicated by the arrow on the casting.

Prepare Piping and Install Valve (Fig. 6).

1. Use new, properly reamed pipe free from chips.
2. Do not thread the pipe too far. Valve distortion or malfunction can result from excess pipe in the valve.
3. Apply good quality pipe dope, resistant to the action of LP gas; put a moderate amount of pipe dope on the pipe threads (not the valve threads). If pipe dope lodges on the valve seat, it can prevent proper closure.
4. Install the valve in a horizontal pipe line in an upright position with the gas flow in the direction indicated by the arrow on the casing.
5. Apply a parallel jaw wrench only to the flat next to the pipe being installed. A wrench applied to the valve body itself or to the end farthest from the pipe being inserted can distort the casting and cause a malfunction.
6. The gas flow must be in the same direction as the arrow on the bottom of the valve body.
7. The V4943/V8943 combination valve pressure regulating sections are provided with integral vent limiters and threaded connections for vent piping (integral 5/16—24 UNF). If piping to the outdoors is required, use 204480 vent fitting.

⚠ WARNING

Prevent Possible Explosion/Fire Hazard

Install the valve so the gas flow is in the same direction as the arrow on the bottom of the valve bottom.

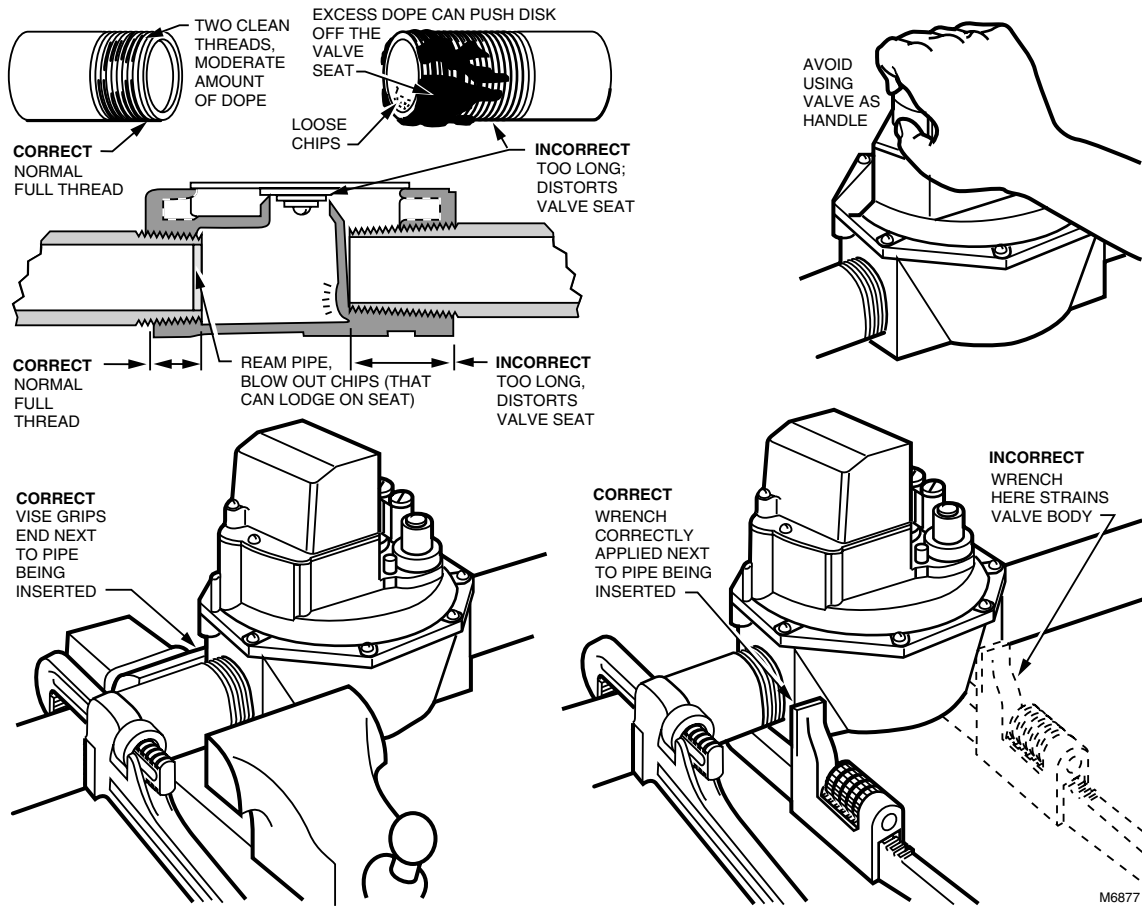

Fig. 6. Preparing piping and installing valve.

8. Make electrical connections as shown in Fig. 7 and 8.
9. Turn on the main gas and, with a soap solution, check the valve installation for leaks.

10. When the rate of bubbles coming through the water stabilizes, count the number of bubbles appearing during a ten-second period. Each bubble appearing during a ten-second period represents a flow rate of approximately 0.001 cfh.

Valve Leak Test (See Fig. 7).

This test checks the tightness closure of a gas safety shutoff valve. It should be performed by a qualified technician during the initial startup of a burner system, or whenever the valve is replaced (see SERVICE INFORMATION section). It is recommended that this test also be included in scheduled inspection and maintenance procedures. For a periodic inspection test, follow steps 1, 3, 4, 5, 8, 9, 10, 12, 13, 16 and 17.

1. De-energize the control system to make sure there is no power to the safety shutoff valve (C) shown in Fig. 8.
2. Close the upstream manual gas cock (A).
3. Make sure the manual test petcock (F) is closed in the leak test tap assembly (D).
4. Remove the leak test tap plug (valve outlet pressure tap can be used as a test tap) and connect the test apparatus to the leak test tap (D).
5. Close the downstream manual gas cock (E).
6. Open the upstream manual gas cock (A).
7. Run the safety shutoff valve (C) to its fully open position (through the safety system); then immediately de-energize the system to close the valve.
8. Immerse a 1/4 in. tube vertically 1/2 in. (13 mm) into a jar of water.
9. Slowly open the test petcock (F).

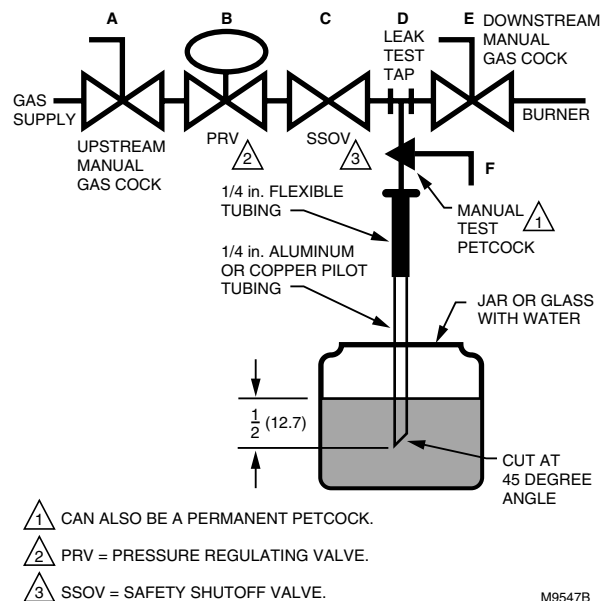

Fig. 7. Valve leak test.

To meet U.S. requirements, leakage must not exceed the following values. See Table 4.

Table 4. Allowable Leakage Rates.

Pipe Size (in.)	Allowable ^a Leakage	Number of Bubbles per 10 sec
1, 1-1/4	353	13
1-1/2, 2	453	16

^a Based on air standard conditions, test pressures in accordance with ANSI Z21.21, Section 2.4.2 and a maximum of 235 cc/h per inch of seal-off-diameter. Seal-off diameter is not the same as pipe size.

11. Close the upstream manual gas cock (A).
12. Close the test petcock (F), remove the test apparatus, and replace the leak test tap plug (D).
13. Open the upstream manual gas cock (A) and energize the safety shutoff valve (C).
14. Test with soap bubbles to make sure there is no leak at the test tap (D).
15. De-energize the safety shutoff valve (C).
16. Open the downstream manual gas cock (E).
17. Restore the system to normal operation.

WIRING

1. Disconnect power supply before making wiring connections to prevent electrical shock and equipment damage.
2. All wiring must comply with applicable electrical codes, ordinances, and regulations. Use NEC Class 1 (line voltage) wiring.
3. For normal installations, use moisture-resistant number 14 wire suitable for at least 167°F (75°C) when using a Flame Safeguard Primary Control or a Flame Safeguard Programming Control.
4. For high temperature installations, use moisture-resistant number 14 wire, selected for a temperature rating above the maximum operating temperature.
5. Check the power supply circuit. The voltage and frequency must match those of the valve.
6. Refer to Fig. 8 and 9 for typical field wiring connections. Follow the burner manufacturer wiring diagram if provided.
7. Make wiring connections using the wires provided with the valve.

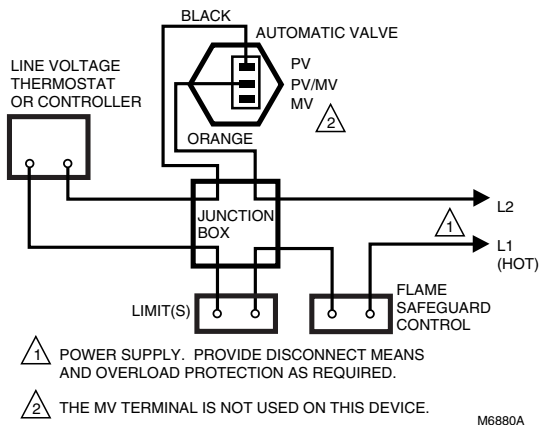

Fig. 8. Typical wiring diagram for V4943A Valve.

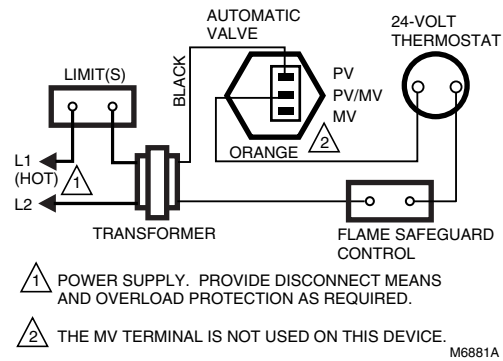

Fig. 9. Typical wiring diagram for V8943A Valve.

OPERATION

Operation of V4943A/V8943A Valves

When the controller is not calling for heat, the valve solenoid coil is not energized. The plunger in the actuator is in the down position, closing the bleed port and opening the supply port. The inlet gas flows into the upper portion of the valve until the gas pressure above and below the diaphragm is equalized. The valve closes and remains closed due to the combined forces of gas and spring pressures.

On a call for heat, the controller contacts close and the valve solenoid coil is energized. The gas above the diaphragm bleeds to the downstream outlet of the valve.

As the gas bleeds from above the diaphragm, the gas pressure is greater below the diaphragm than above and the valve begins to open. When the gas pressure above the diaphragm reaches its minimum value (burner delivery pressure), the valve fully opens.

After the controller is satisfied, the procedure is reversed. The controller contacts open and the solenoid coil is de-energized. The plunger is released, moving to the down position. The bleed port closes and the supply port opens, allowing gas to flow above the diaphragm. As the gas pressure above the diaphragm increases, the diaphragm moves downward and the valve begins to close. When the gas pressures above and below the diaphragm are equal, the valve fully closes. Spring pressure assists in closing the valve. If the inlet gas supply fails and there is no gas pressure above the diaphragm, the spring pressure is enough to close the valve.

In the event of a power failure during automatic operation of the valve, the V4943A/V8943A Valves close. Normal operation resumes on the restoration of power.

CHECKOUT AND TROUBLESHOOTING

WARNING

Prevent Possible Explosion Hazard

Do not let fuel accumulate in the combustion chamber. If fuel is allowed to enter the chamber for longer than a few seconds without igniting, an explosive mixture could result.

WARNING

Prevent Possible Explosion Hazard

Do not put the system into service until you have satisfactorily completed all applicable tests described in the Checkout section of the instructions for the flame safeguard control, and any other tests required by the burner manufacturer.

Close all manual fuel shutoff valves as soon as trouble occurs.

Checkout

1. Check the performance of the valve by measuring the pressures at the inlet and outlet pressure taps at the bottom of the valve. The pressure reading at the outlet tap can be slightly higher than a downstream measurement due to dynamic gas flow effects. The measurement at the outlet tap is for reference only.
2. Shut off the gas supply to the valve and make sure the valve is closed when setting up pressure measuring equipment.
3. Set the thermostat or controller to energize the valve and check the final outlet pressure.
4. Start the system and observe its operation through at least one complete cycle to make sure the valve functions as described in the Operation section.

Troubleshooting

CAUTION

Electrical shock or equipment damage hazard.

Use extreme care during troubleshooting. Line voltage is present at the actuator for the V4943A Valves, and present in all controller circuits for all V4943A/V8943A Valves.

IMPORTANT

Do not assume that the valve must be replaced until after all other sources of trouble are eliminated.

The Valve will not Open When Thermostat or Controller Calls for Heat

1. Check that there is voltage at the valve actuator leadwires or terminal block. Be careful of any line voltage at the actuator of the V4943A Valves.
2. If there is no voltage at the actuator, first make sure line voltage power is connected to the master switch, the master switch is closed and overload protection (circuit breaker, fuse or similar device) has not opened the power line.
3. For V8943A only, if line voltage power is correct, check the transformer output. Replace the transformer if necessary.
4. If there is still no voltage at the actuator, make sure all appropriate contacts in the thermostat or controller, limits and flame safeguard control are closed. If one or more is open, determine the cause(s) and correct the condition(s) before proceeding.
5. If there is proper voltage at the valve actuator but the valve still does not open, first check that the gas pressure at the valve is normal.
6. If the valve still does not open, replace the valve.

The Valve does not Open When One or More Appropriate Contacts in Thermostat or Controller, Limit(s) or Flame Safeguard Control is Open

1. Make sure that the gas flow is in the direction of the arrow on the valve body.
2. Make sure the valve actuator is wired in the correct circuit.
3. Open the master switch to remove power from the valve actuator. If the valve does not close, the actuator may not be wired properly.
4. Check and correct the wiring, if necessary.
5. Look for a possible short in the electrical circuit.

Service Information

CAUTION

Prevent Electrical Shock/Equipment Damage

- Only qualified service technicians should attempt to service or repair flame safeguard controls and burner systems.
- Line voltage is present in the electrical circuits to the valve. Open the master switch before replacing the valve.

Scheduled Inspection and Maintenance

For periodic inspection and maintenance, set up a schedule and follow it. Include the burner valves and all other controls. For more information, refer to the flame safeguard control instructions.

Home and Building Control

Honeywell Inc.
Honeywell Plaza
P.O. Box 524
Minneapolis MN 55408-0524

Honeywell Latin American Region

480 Sawgrass Corporate Parkway
Suite 200
Sunrise FL 33325

Home and Building Control

Honeywell Limited-Honeywell Limitée
155 Gordon Baker Road
North York, Ontario
M2H 3N7

Honeywell Europe S.A.

3 Avenue du Bourget
1140 Brussels
Belgium

Honeywell Asia Pacific Inc.

Room 3213-3225
Sun Hung Kai Centre
No. 30 Harbour Road
Wanchai
Hong Kong

Honeywell